

City of Mercer Island
Community Planning & Development
Project Number: **2502-039**
Grace Manahan

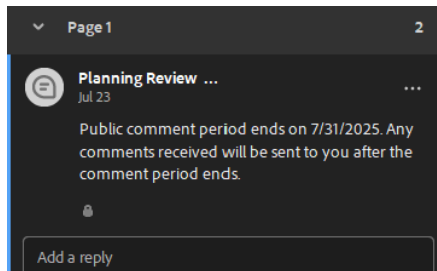

Hello Grace

Below you will find the response to your field request dated 7/23/2025 for the above noted project. If you have any questions regarding the responses or would like me to clarify something you will find all of my contact information below. Thanks.



1. Revisions provided

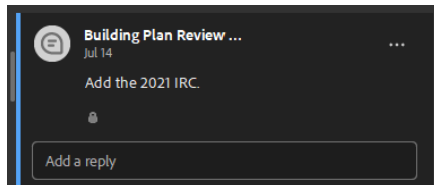

2. 2021 IRC added to List of Codes – Cover Sheet 1 of 14

Building Plan Review ...
Jul 14

Note to applicant: Many outdoor BBQ's (even if they are listed) do not allow installation under a cover explicitly in their installation manual. I would mention that the testing standard prohibits this. A common issue is the definition of "combustible materials" which most residences in the city of Mercer Island (TYPE V/B) are constructed and do not allow the installation per many BBQ manuals. The city has identified some review paths provided prescribed in [three] categories.

1) - An alternative the applicant may want to consider for an outdoor appliance is an **M1503.2.1** Open-Top Broiler Exhaust - which is easier to review and permit for applications under cover. If the applicant intends to pursue this path, please describe compliance with and list all requirements on the plans of **M1503.2.1** and verbatim list the exceptions on plans if used.

2) - Provide make and model of outdoor gas cooking appliances with listed and labelled approved for use under cover and specify on plan that the manufacturer's specifications and clearances will be provided. **C2404.3 (301.3)**. If the applicant intends to pursue this path, provide make and model and installation manual for review and approval.

3) - The city of Mercer Island will require a code alternate application for application of anything different than stated in the manufacturer's manual. A letter from the manufacturer is not

3. Outdoor Kitchen Removed – the comment is no longer applicable

Building Plan Review ...
Jul 16

correct to 2021

Reply

4. Main Floor General Notes revised to reflect 2021 IRC – Layout 2 of 14

Building Plan Review ...
Jul 14

Specify fuel source for all interior and exterior fireplaces. If other than direct vent natural gas more information will be required on each type of fireplace and chimney assembly. If direct vent, specify vent location. Per **IMC 303.3, M1804.2.6**

5. Fireplace specifications provided – gas fireplace is equipped with direct venting – vent location specified per IMX 303.3 & M1804.2.6 Floor Plan - Layout 2 of 14

Building Plan Review ...
Jul 14

Correct CFM:
Kitchen's minimum: 160 Cfm intermittent electric range. 250 Cfm combustion range. If downdraft 300 cfm intermittent required. Per **M1505.4.4(1)**.
List all options or specify hood type

6. Range Vent note revised to reflect 250CFM – combustion range. Layout 2 of 14

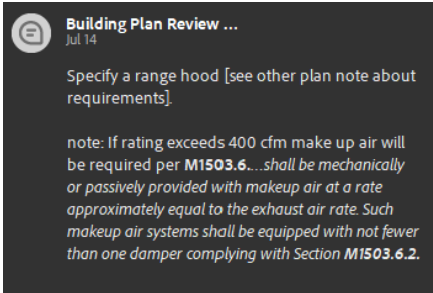

7. Prep kitchen Hood called out as 250 CFM - combustion range. Layout 2 of 14

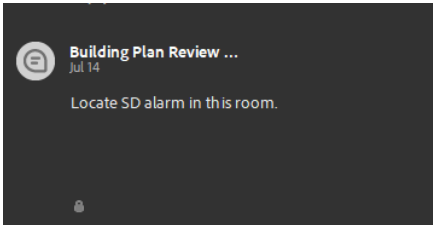

8. SD alarm added to Home Office.

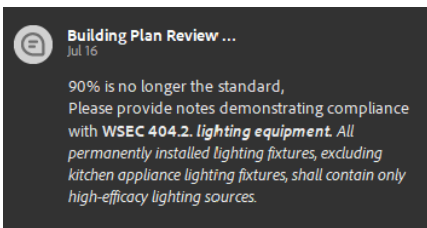

9. Note removed from Layout 2 of 14 – note was related to remodels additions and not new construction.

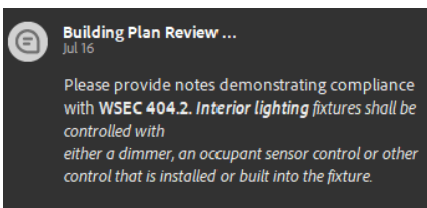

10. Note added to Layout 2 of 14

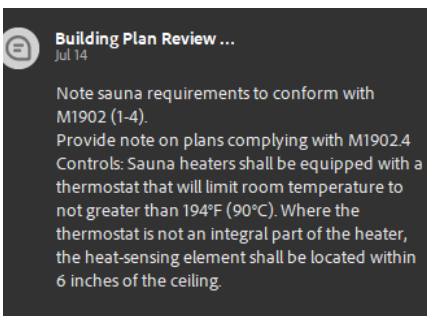

11. Note added to layout 3 of 14

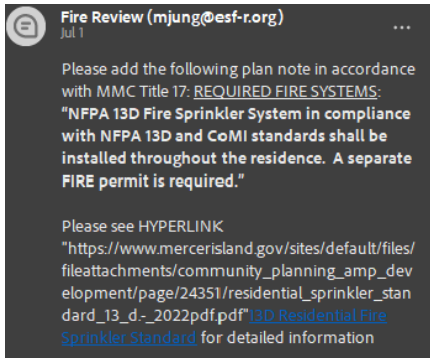

12. Note added to Layout 3 of 14

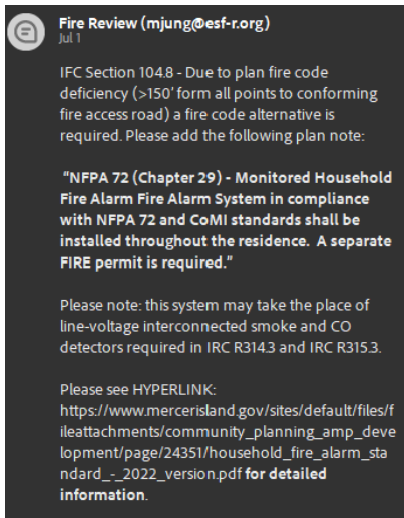

13. Note added to Layout 3 of 14

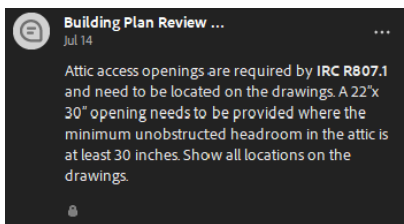

14. 24x30 attic access added to Main & Upper Floor. Layout 2 of 14 and 3 of 14.

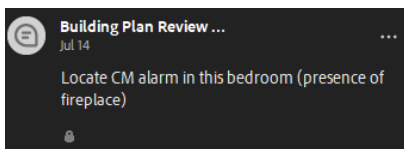

15. CO – Added to Primary Bedroom – presence of fireplace. Layout 3 of 14

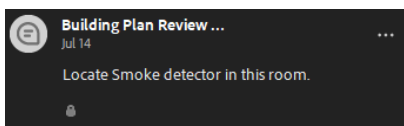

16. SD – Added to Primary WIC. Layout 3 of 14

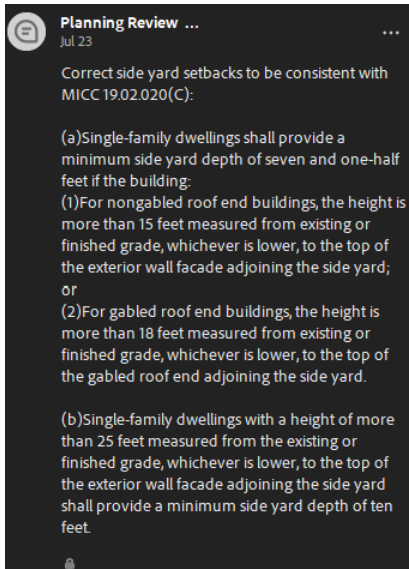

17.

Side yard – setback revised to match the MICC 19.02.020 © - Line (a) – Single-family dwellings shall provide a min. side yard depth of seven and one-half feet.

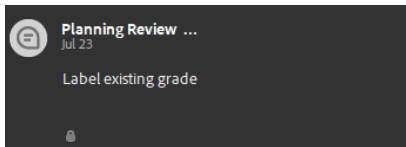

18.

Existing Grade Labeled on front elevation. Layout 7 of 14

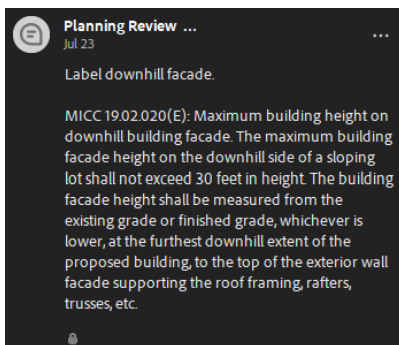

19.

Downhill Façade Labeled – Layout 8 of 14

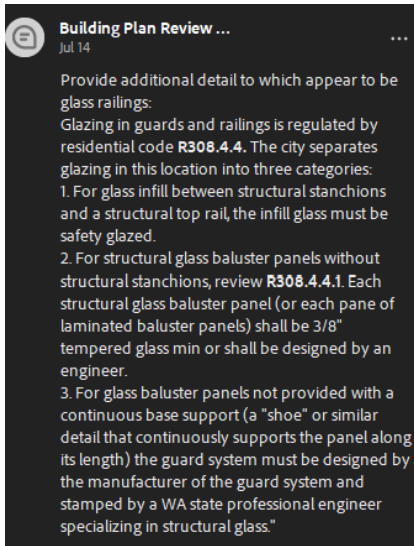

20.

Engineering reports provided – for Glass Railings- attached to this response letter. The report is to be printed and kept at the job site with the approved set of plans.

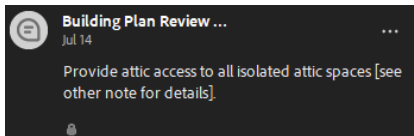

21.

Attic access provided on cross sections – Layout 10 of 14

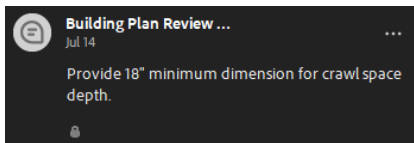

22.

Dimension added to crawls space – Cross sections B – Layout 10 of 14. Min. of 18"

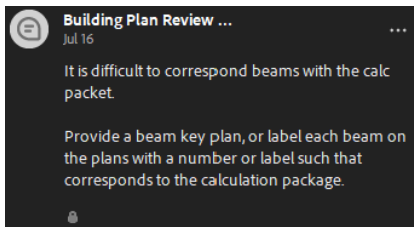

23.

Comment Addressed by O.L. Olsen & Associates Inc. – Layout S.3

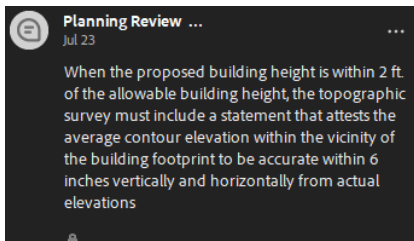

24.

Comment addressed by Goodman Engineering PLLC – Layout C1

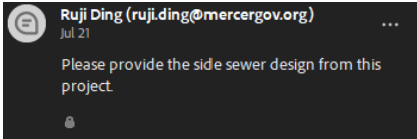

25. Comment addressed by Goodman Engineering PLLC – Layout C1

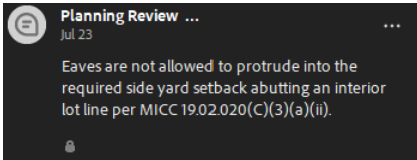

26. Comment addressed by Goodman Engineering PLLC – Layout C1

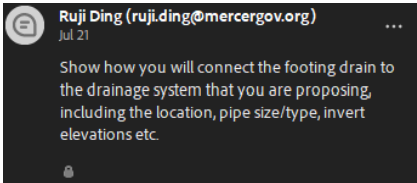

27. Comment addressed by Goodman Engineering PLLC – Layout C1

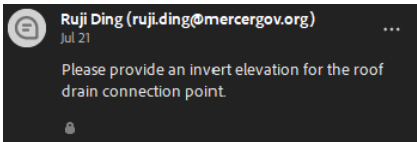

28. Comment addressed by Goodman Engineering PLLC – Layout C1

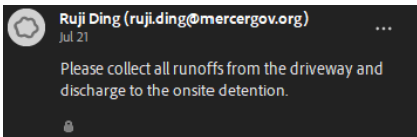

29. Comment addressed by Goodman Engineering PLLC – Layout C1

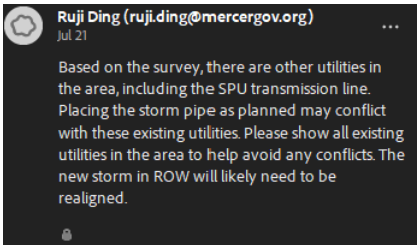

30. Comment addressed by Goodman Engineering PLLC – Layout C1

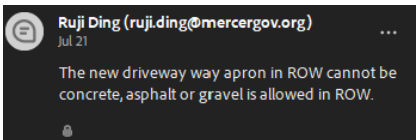

31. Comment addressed by Goodman Engineering PLLC – Layout C1

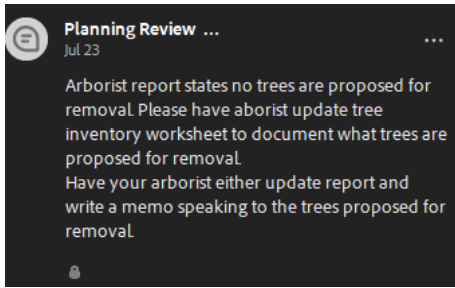

32.

Comment addressed by Goodman Engineering PLLC – Layout C1

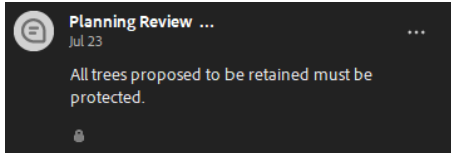

33.

Comment addressed by Goodman Engineering PLLC – Layout C1

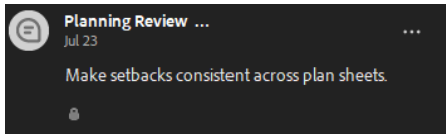

34.

Comment addressed by ALODR LLC – Layout – Site Plan

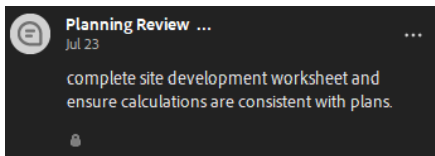

35.

Comment addressed by ALODR LLC – Layout – Site Plan

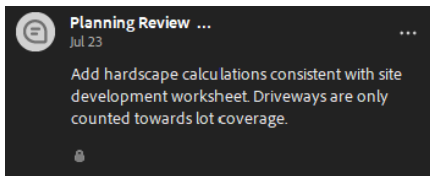

36.

Comment addressed by ALODR LLC – Layout – Site Plan

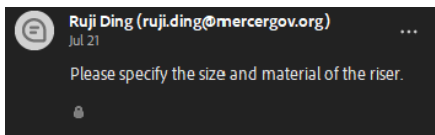

37.

38. Comment addressed by Goodman Engineering PLLC

Architecture + Construction

ALDOR LLC.

Dorin Cornitel

26809 199th Ave SE.

Covington WA. 98042

(206)-747-8421

ALDOR.architecture.construction@outlook.com

heatilator[®]
The first name in fireplaces



Novus Series

Novus | Novus nXt | Novus Evolution

Novus

direct vent & b-vent gas fireplaces



Traditional Style, Proven Value

The Novus is the best-selling gas fireplace of all time. Why? Stylish design elements and robust fires—paired with the proven value and dependability of Heatilator. Glowing embers, realistic logs and endless finishing options add character to any space. Trust in the industry's most recognized brand. The Novus will deliver.

Above: Novus shown with plymouth mantel and absolute black granite

Features

- 30", 33", 36" or 42" viewing areas
- Many installation possibilities including tight spaces and corners
- Make it your own with multiple fronts, finishes and traditional brick panels



IntelliFire™ Ignition System

The IntelliFire™ Ignition System (IPI) is an advanced intermittent pilot ignition system. IPI constantly monitors ignition, ensures safe functioning and conserves up to \$10/month in energy costs. To learn more, visit heatilator.com.

Direct Vent Technology

Direct Vent fireplaces remove 100% of combustion exhaust and odors outside of the home. These sealed fireplaces provide optimal heat, conserve energy and ensure clean, safe indoor air quality. To learn more, visit heatilator.com.

Options

Fronts



Tres Front Black

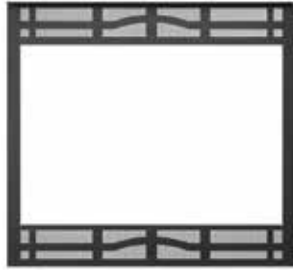

Demi Front Black

Front Finishes

Finish options shown available for the optional Demi front.

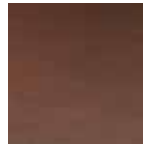

Bronze

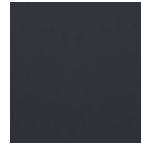

Black

Refractory



Traditional Refractory

Controls

TotalRemote This remote control effortlessly manages heat output and comfort level. For fireplaces and inserts.

Models: RCT-MLT-HTL

Features: Hardwired Receiver, Timer Mode, Thermostat Mode, Room Temperature Readout, Flame High/Low, Fan Speed, On/Off



SmartRemote An added level of function and convenience in a remote control. For fireplaces, stoves, inserts, and gas logs with or without line power.

Models: SMARTBATHTL-B, SMART-STAT-HTL

Features: Battery-Powered or Hardwired Receiver, Timer Mode, Thermostat Mode, Room Temperature Readout, On/Off



IntelliSwitch200 This wall switch is designed exclusively for Heatilator fireplaces with the IntelliFire ignition system.

Models: WSK200-HTL

Features: On/Off, Auto Battery Backup, Battery Strength Indicator, Pilot Activation, Fan Speed



Additional Options Not Pictured

- Fan Kit
- Outside Air Kit (for B-vent models only)
- Gas Conversion Kits
- Mantels and Surrounds

Venting

- Direct Vent: DVP pipe
- B-Vent: 5" B-vent pipe

Technical Specifications

MODEL	FRONT WIDTH (A)	BACK WIDTH (C)	HEIGHT	DEPTH	OPENING SIZE	BTU/HR INPUT(NG)
NBV/NDV3630I	35" (889mm)	8-5/8" (219mm)	35-14" (896mm)	9-1/8" (486mm)	30" (762mm)	14,000 - 20,000
NBV/NDV3933I	38" (965mm)	11-5/8" (295mm)	35-14" (896mm)	19-1/8" (486mm)	33" (838mm)	15,000 - 22,000
NBV/NDV4236I	41" (1041mm)	14-5/8" (371mm)	35-14" (896mm)	19-1/8" (486mm)	36" (914mm)	17,000 - 25,000
NBV/NDV4842I	47" (1194mm)	20-5/8" (524mm)	35-14" (896mm)	19-1/8" (486mm)	42" (1067mm)	20,500 - 30,000

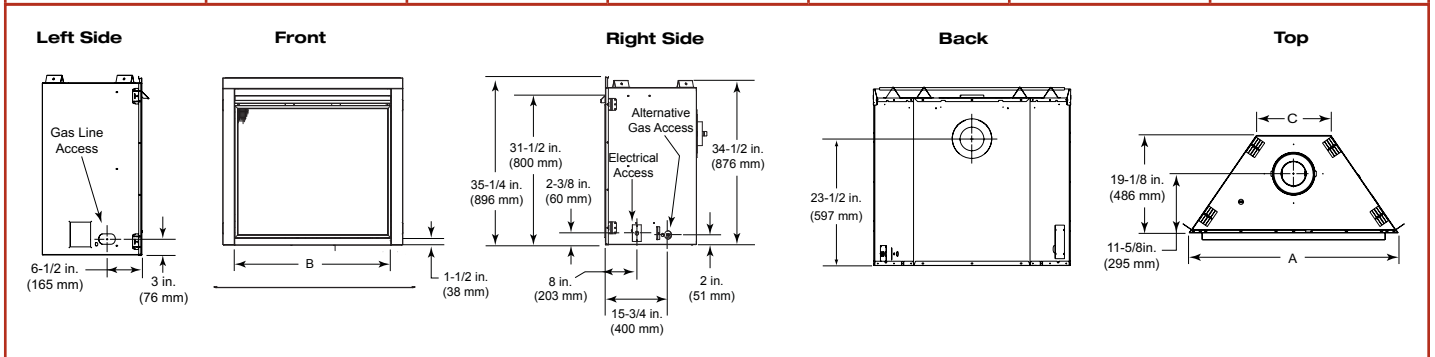

U.S. Efficiencies

Steady State - Since most homeowners use their fireplaces for an extended time while they are in the room, Steady State measures how efficiently your fireplace converts fuel to heat once it is warmed up and running in a "steady state". **AFUE** - AFUE rating is more typically used with appliances, like your furnace, that continually cycle on and off to maintain a constant temperature.

Canada Efficiencies

EnerGuide (CSA P.4.1-02) - EnerGuide is a rating used in Canada to measure annual fireplace efficiency.

Rating	NDV3630	NDV3933	NDV4236	NDV4842
Steady State	75%	78%	73%	77%
AFUE	52%	48%	52%	56%

Rating	NDV3630	NDV3933	NDV4236	NDV4842
EnerGuide (CSA P.4.1-02)	55%	51%	54%	58%

Novus nXt

direct vent gas fireplaces



Traditional Style, *Proven Value, 2.0*

The Novus nXt is the second generation of the best-selling gas fireplace of all time. Design enhancements create a more sleek finish and robust fireside experience. Technology upgrades include 5 flame intensity settings and enhanced efficiency. Experience the value of Heatilator. Enjoy the Novus nXt for years to come.

Above: Novus nXt shown standard with custom surround

Features

- 33" or 36" viewing area
- Brick interior enhances flame and glowing embers
- Detailed 7-piece log set
- 69% AFUE efficiency rating
- Standard fan helps distribute warmth out into the room
- Make it your own with multiple fronts, finishes and optional fan

IntelliFire™ Ignition System

The IntelliFire™ Ignition System (IPI) is an advanced intermittent pilot ignition system. IPI constantly monitors ignition, ensures safe functioning and conserves up to \$10/month in energy costs. To learn more, visit heatilator.com.

Direct Vent Technology

Direct Vent fireplaces remove 100% of combustion exhaust and odors outside of the home. These sealed fireplaces provide optimal heat, conserve energy and ensure clean, safe indoor air quality. To learn more, visit heatilator.com.

Standard Features

Front



Simon Front

Refractory



Traditional Refractory

Fan Kit

A standard 100 CFM fan kit quietly extends the heating range of the nXt.

IntelliFire Plus

Wireless Control

IntelliFire Plus RC200 Designed to wirelessly control the Novus nXt, the RC200 can be docked on a wall to mimic a thermostat, or used as a remote.

Features: Auto Battery Backup, Battery Strength Indicator, Pilot Activation, On/Off, 5 Step Flame Height, Fan Speed, Child Lock



Upgrade Options

Fronts

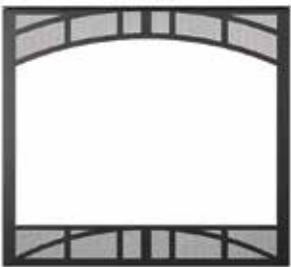

Tres Front Black

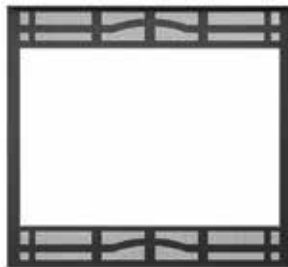

Demi Front Black

Finish options shown here available for the Demi front.



Bronze

Black

IntelliFire Plus

Wireless Control

IntelliFire Plus RC300 Designed to wirelessly control the Novus nXt. A large LCD screen and simple navigation provide easy operation. The RC300 can be docked on the wall to mimic a thermostat, or used as a remote.

Features: Auto Battery Backup, Pilot Activation, On/Off, 5 Step Flame Height, Fan Speed (auxiliary 1), two additional Auxiliary Functions, Room Temperature Readout, Thermostat Mode, Timer Mode, Child Lock



Additional Options Not Pictured

- Gas Conversion Kits
- Mantels and Surrounds

Venting

- Direct Vent: DVP pipe

Technical Specifications

MODEL	FRONT WIDTH (A)	BACK WIDTH (C)	HEIGHT	DEPTH	OPENING SIZE	BTU/HR INPUT(NG)
NNXT3933I	38" (965mm)	11-5/8" (295mm)	35-1/4" (896mm)	19-1/8" (486mm)	33" (838mm)	16,000 - 29,000
NNXT4236I	41" (1041mm)	14-5/8" (371mm)	35-1/4" (896mm)	19-1/8" (486mm)	36" (914mm)	18,500 - 31,000

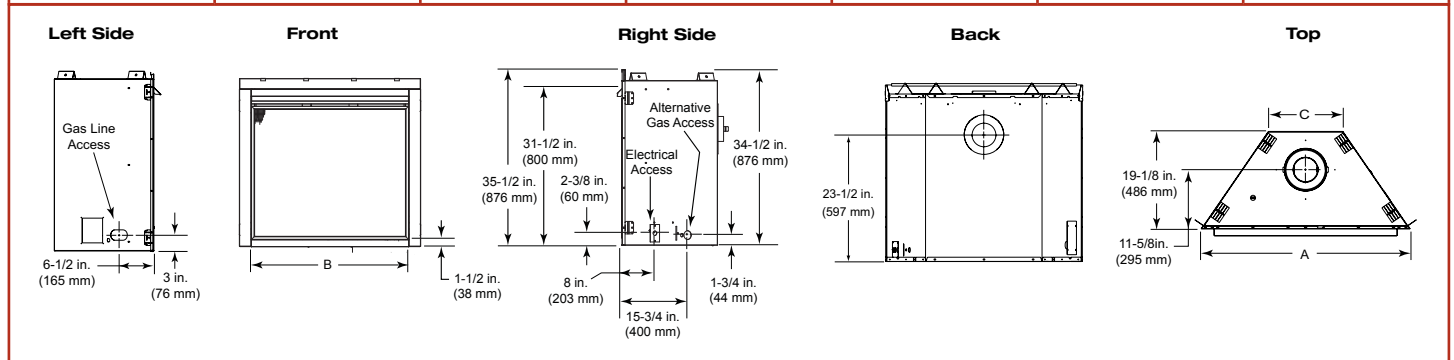

U.S. Efficiencies

Steady State - Since most homeowners use their fireplaces for an extended time while they are in the room, Steady State measures how efficiently your fireplace converts fuel to heat once it is warmed up and running in a "steady state". **AFUE** - AFUE rating is more typically used with appliances, like your furnace, that continually cycle on and off to maintain a constant temperature.

Rating	NNXT3933I	NNXT4236I
Steady State	82%	81%
AFUE	70%	69%

Canada Efficiencies

EnerGuide (CSA P.4.1-02) - EnerGuide is a rating used in Canada to measure annual fireplace efficiency.

Rating	NNXT3933I	NNXT4236I
EnerGuide (CSA P.4.1-02)	72%	72%

Novus Evolution

direct vent gas fireplaces



The Next Generation of Value

The Novus Evolution is the latest generation of the best-selling gas fireplace of all time. This modern unit blends fashionable style with advanced technology. A sleek design lets the Evolution's clean lines and contemporary elements shine. A porcelain interior and unique glass media highlight artistic flames. Experience the latest Evolution of proven Heatilator value.

Above: Novus Evolution-36 shown with clear glass media, cinema front in black and custom granite.

Features

- 30" or 36" viewing area
- Multiple media, front and finishing options
- Reflective porcelain interior
- Adjustable flame and heat intensity levels

IntelliFire™ Ignition System

The IntelliFire™ Ignition System (IPI) is an advanced intermittent pilot ignition system. IPI constantly monitors ignition, ensures safe functioning and conserves up to \$10/month in energy costs. To learn more, visit heatilator.com.

Direct Vent Technology

Direct Vent fireplaces remove 100% of combustion exhaust and odors outside of the home. These sealed fireplaces provide optimal heat, conserve energy and ensure clean, safe indoor air quality. To learn more, visit heatilator.com.

Options

Front



Cinema Front
(shown with optional finishing trim)

Front Finishes

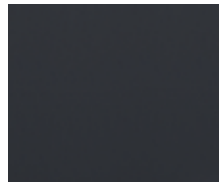

Black



Stainless Steel

Glass Media

Accent your flames with one of four glass colors.



Clear (Included)



Black



Cobalt Blue



Amber

Control Options



IntelliFire Plus RC300 Designed to wirelessly control the Evolution. A large LCD screen and simple navigation provide easy operation. The RC300 can also be docked on the wall to mimic a thermostat, or used as a remote.

Features: Auto Battery Backup, Pilot Activation, On/Off, 5 Step Flame Height, Fan Speed (auxiliary 1), two additional Auxiliary Functions, Room Temperature Readout, Thermostat Mode, Timer Mode, Child Lock and Wall Docking Station



IntelliFire Plus RC200 Designed to wirelessly control the Evolution. The RC200 can also be docked on the wall to mimic a thermostat, or used as a remote.

Features: Auto Battery Backup, Battery Strength Indicator, On/Off, Pilot Activation, 5 Step Flame Height, Fan Speed, Child Lock and Wall Docking Station



IntelliFire Plus RC100 Designed exclusively for Heatilator fireplaces with the IntelliFire ignition system.

Features: On/Off



Easy Switch Controls the most basic functions of the fireplace—on/off—in the easiest way possible.

Models: WSK-21-HTI, WSK-21-W-HTI

Features: On/Off

Venting

- Direct Vent: DVP pipe or SLP pipe

Additional Options Not Pictured

- Gas Conversion Kits
- Mantels and Surrounds

Technical Specifications

MODEL	FRONT WIDTH (A)	BACK WIDTH (C)	HEIGHT	DEPTH	OPENING SIZE	BTU/HR INPUT(NG)
NEVO3630I	35" (889mm)	8-5/8" (219mm)	39-1/8" (994mm)	19-1/8" (486mm)	30" (762mm)	10,000 - 20,000
NEVO4236I	41" (1041mm)	14-5/8" (371mm)	39-1/8" (994mm)	19-1/8" (486mm)	36" (914mm)	12,500 - 25,000

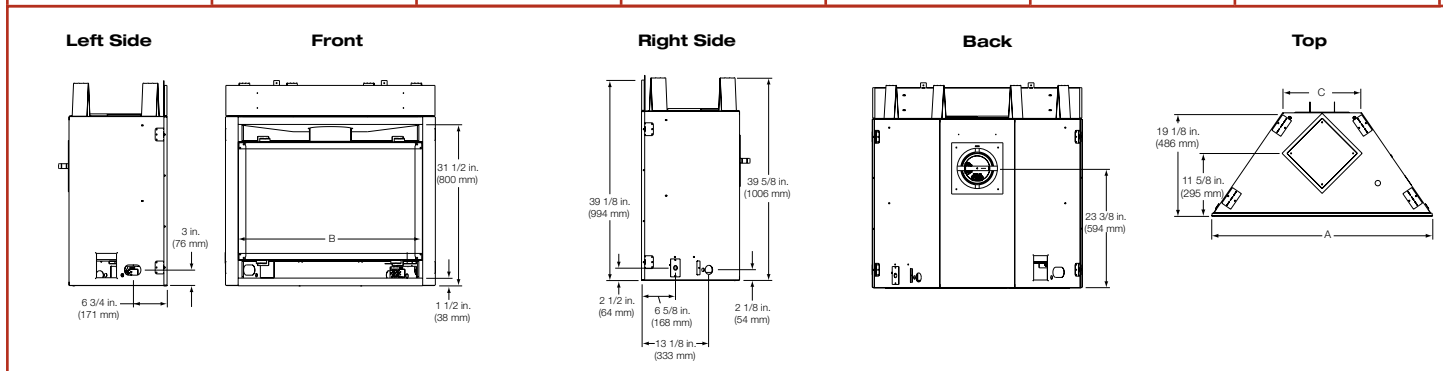

U.S. Efficiencies

Steady State - Since most homeowners use their fireplaces for an extended time while they are in the room, Steady State measures how efficiently your fireplace converts fuel to heat once it is warmed up and running in a "steady state". **AFUE** - AFUE rating is more typically used with appliances, like your furnace, that continually cycle on and off to maintain a constant temperature.

Canada Efficiencies

EnerGuide (CSA P.4.1-02) - EnerGuide is a rating used in Canada to measure annual fireplace efficiency.

Rating	NEVO3630I	NEVO4236I
Steady State	69%	71%
AFUE	53%	54%

Rating	NEVO3630I	NEVO4236I
EnerGuide (CSA P.4.1-02)	54%	58%

Clearances

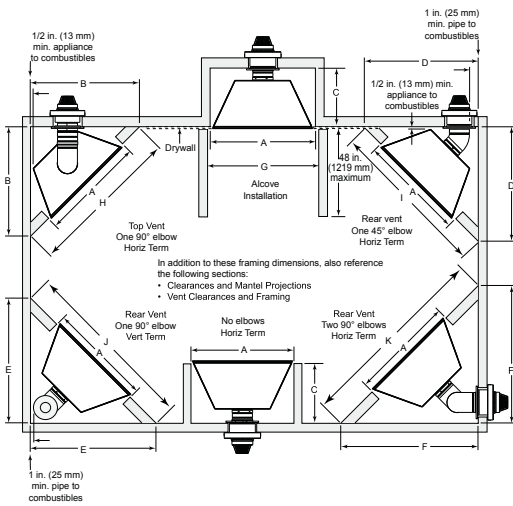

NOVUS	A	B	C	D	E	F	G	H	I	J	K
NBV/NDV3630I	36" (914mm)	33-1/2" (851mm)	19-5/8" (498mm)	43-3/8" (1102mm)	47" (1194mm)	53-1/4" (1353mm)	37" (940mm)	47-3/8" (1203mm)	61-3/8" (1559mm)	66-1/2" (1689mm)	75-3/8" (1915mm)
NBV/NDV3933I	39" (991mm)	35-1/2" (902mm)	19-5/8" (498mm)	43-3/8" (1102mm)	47" (1194mm)	53-1/4" (1353mm)	40" (1016mm)	50-1/4" (1276mm)	61-3/8" (1559mm)	66-1/2" (1689mm)	75-3/8" (1915mm)
NBV/NDV4236I	42" (1067mm)	37-5/8" (956mm)	19-5/8" (498mm)	43-3/8" (1102mm)	47" (1194mm)	53-1/4" (1353mm)	43" (1092mm)	53-1/4" (1353mm)	61-3/8" (1559mm)	66-1/2" (1689mm)	75-3/8" (1915mm)
NBV/NDV4842I	48" (1219mm)	41-7/8" (1064mm)	19-5/8" (498mm)	43-3/8" (1102mm)	47" (1194mm)	53-1/4" (1353mm)	49" (1245mm)	59-1/4" (1505mm)	61-3/8" (1559mm)	66-1/2" (1689mm)	75-3/8" (1915mm)
NOVUS NXT	A	B	C	D	E	F	G	H	I	J	K
NNXT3933I	39" (991mm)	35-1/2" (902mm)	19-5/8" (498mm)	43-3/8" (1102mm)	47" (1194mm)	53-1/4" (1353mm)	40" (1016mm)	50-1/4" (1276mm)	61-3/8" (1559mm)	66-1/2" (1689mm)	75-3/8" (1915mm)
NNXT4236I	42" (1067mm)	37-5/8" (956mm)	19-5/8" (498mm)	43-3/8" (1102mm)	47" (1194mm)	53-1/4" (1353mm)	43" (1092mm)	53-1/4" (1353mm)	61-3/8" (1559mm)	66-1/2" (1689mm)	75-3/8" (1915mm)
NOVUS EVOLUTION	A	B	C	D	E	F	G	H	I	J	K
NEVO3630I	36" (914mm)	33-1/2" (851mm)	19-5/8" (498mm)	43-3/8" (1102mm)	47" (1194mm)	53-1/4" (1353mm)	37" (940mm)	47-3/8" (1203mm)	61-3/8" (1559mm)	66-1/2" (1689mm)	75-3/8" (1915mm)
NEVO4236I	42" (1067mm)	37-5/8" (956mm)	19-5/8" (498mm)	43-3/8" (1102mm)	47" (1194mm)	53-1/4" (1353mm)	43" (1092mm)	53-1/4" (1353mm)	61-3/8" (1559mm)	66-1/2" (1689mm)	75-3/8" (1915mm)

Framing

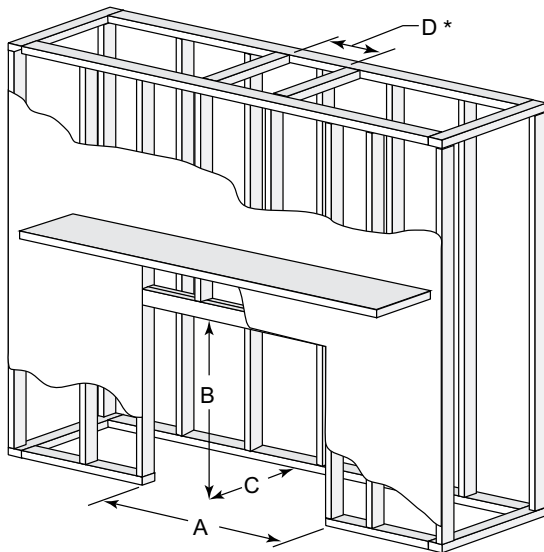

NOVUS	A ROUGH OPENING (WIDTH)	B ROUGH OPENING (HEIGHT)	C ROUGH OPENING (DEPTH)	D ROUGH OPENING (DVP PIPE)	D ROUGH OPENING (SLP PIPE)
NBV/NDV3630I	36" (914mm)	34-7/8" (886mm)	19-5/8" (498mm)	10" (254mm)	9" (229mm)
NBV/NDV3933I	39" (991mm)	34-7/8" (886mm)	19-5/8" (498mm)	10" (254mm)	9" (229mm)
NBV/NDV4236I	42" (1067mm)	34-7/8" (886mm)	19-5/8" (498mm)	10" (254mm)	9" (229mm)
NBV/NDV4842I	48" (1219mm)	34-7/8" (886mm)	19-5/8" (498mm)	10" (254mm)	9" (229mm)
NOVUS NXT	A ROUGH OPENING (WIDTH)	B ROUGH OPENING (HEIGHT)	C ROUGH OPENING (DEPTH)	D ROUGH OPENING (DVP PIPE)	D ROUGH OPENING (SLP PIPE)
NNXT3933I	39" (991mm)	34-7/8" (886mm)	19-5/8" (498mm)	10" (254mm)	9" (229mm)
NNXT4236I	42" (1067mm)	34-7/8" (886mm)	19-5/8" (498mm)	10" (254mm)	9" (229mm)
NOVUS EVOLUTION	A ROUGH OPENING (WIDTH)	B ROUGH OPENING (HEIGHT)	C ROUGH OPENING (DEPTH)	D ROUGH OPENING (DVP PIPE)	D ROUGH OPENING (SLP PIPE)
NEVO3630I	36" (914mm)	39-7/8" (1013mm)	19-5/8" (498mm)	10" (254mm)	9" (229mm)
NEVO4236I	42" (1067mm)	39-7/8" (1013mm)	19-5/8" (498mm)	10" (254mm)	9" (229mm)

* For B-Vent pipe clearance dimensions, please refer to pipe manufacturers installation specifications.

Available From

heatilator
The first name in fireplaces

800-927-6841 | heatilator.com

facebook.com/Heatilator

twitter.com/Heatilator

youtube.com/HeatilatorFireplaces

Canada

ENERGUIDE

Look for the EnerGuide Gas Fireplace Energy Efficiency Rating in this brochure

Based on CSA P4-1-02

UL LISTED

Limited Lifetime Warranty*

The strongest in the industry, Heatilator provides a limited lifetime warranty on gas-burning products of the most important aspects: firebox and heat exchanger.

*For full warranty details go to heatilator.com.

The information provided in this literature is for planning purposes only and subject to change. Please consult the installation manual for actual installation. Actual product appearance may differ from product images.

Fireplace glass and other surfaces get extremely HOT and can cause severe burns if touched. Do not remove the protective safety screen from the front of the glass. Keep a safe distance away. To learn more visit: www.heatilator.com/fireplacesafety.

HTL-1091U-0814

23 August 2019

Architectural Railing Division
C.R. Laurence Co., Inc.
2503 E Vernon Ave.
Los Angeles, CA 90058
(T) 800.421.6144
www.crlaurence.com

SUBJ: GLASS WINDSCREEN SYSTEM
FRAMELESS WINDSCREEN CLAMP SYSTEM
AFWC1/AFWC6, AFWC2/AFWC7, AFWC3/AFWC8, AFWC4, AFWC1S. AFWC4
DFWC3 - ALL VARIANTS
FRICTION FIT CLAMPS FWCR10/12, FWCS10/12, FWCS20/22, FWCR20/22

The frameless windscreen system uses stainless steel clamps to point support fully tempered glass lights. The windscreen system is designed for the following loading conditions:

200 lb concentrated load at top rail or top of glass horizontal (where applicable) or
50 lbs on one square foot at any location on glass (always applicable) or
wind load as shown in attached calculations for specified panel size.

The frameless windscreen clamps may be used for fall protection in one- and two-family residential occupancies and locations included in IBC 1607.8.1 Exceptions 1 and 2 when installed with 3 panels minimum of ½” tempered glass and installed with a top rail capable of spanning 10 feet. Allowable light sizes for fall protection are as indicated in tables 8 and 14. For these conditions the system will support the 200 lb load vertically or horizontally with a design factor of 4.0 against glass failure. Allowable wind loading for given panel height shall be in accordance with tables 5, 6, 10 to 13 or as calculated using the equations herein. This report is valid for glass light lengths from 36” to 72” long and up to 60” tall.

The clamps should be installed at 1/4 the panel length from each end. Clamp locations outside of 1/4 to 1/3 the light length from the ends are outside the scope of this report. Loads on the clamps shall not exceed the values given herein and as summarized in Table 15.

For these conditions the railing meets all applicable requirements of the 2006, 2009, 2012, 2015 and 2018 International Building Codes and 2010, 2013 and 2016 California Building Codes, 2010 and 2013 California Residential Codes and other state and local building codes adopting the International Building Codes. Stainless steel components are evaluated in accordance with SEI ASCE 8-02, *Specification for the Design of Cold-Formed Stainless Steel Structural Members* or AISC Design Guide 27 *Structural Stainless Steel*, as appropriate. The glass components are evaluated in accordance with GANA *Glazing Manual*, *Tempered Glass Engineering Standards Manual* and *Laminated Glazing Reference Manual*. The system may be designed and constructed using the methodology detailed herein to be compliant with ASTM E 2358 *Standard*

EDWARD C. ROBISON, PE
10012 Creviston Dr NW
Gig Harbor, WA 98329
253-858-0855/Fax 253-858-0856 elrobison@narrows.com

Specification for the Performance of Glass in Permanent Glass Railing Systems, Guards, and Balustrades and ICC Acceptance Criteria AC 439 Acceptance Criteria for Glass Railing and Balustrade Systems (July 2015).

Other glass thicknesses- This report provides the glass thicknesses the clamps are designed to support using the provided contact gaskets. Other glass thicknesses may be used but or outside of the scope of this report.

All glass is assumed to be a regular rectangle with the only holes being those used for installation of the clamps. Other glass shapes, such as trapezoidal are outside of the scope of this report. Notches in the glass are outside of the scope of this report.

For fall protection this report is limited to one- and two- family dwellings residential or locations listed in IBC 1607.8.1 exception 2 where the uniform live load is reduced to 20 plf. Any other application requiring fall protection is outside the scope of this report.

The specifier shall verify the suitability of the system for any specific installation to include but not limited to the wind load conditions, fall protection requirements, substrate support and any local codes or other requirements. This report may be used by a qualified professional as a guide in preparing a project specific design.

Contents:	Page:
Stamp Page	3
Load Conditions	4
Glass Strength	5 - 14
Clamps	14 - 44
Clamp Summary Table	45
Determination of Amplification Factors	46 - 50

Sealed 23 AUG 2019

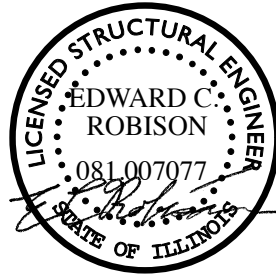
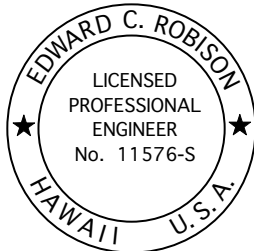
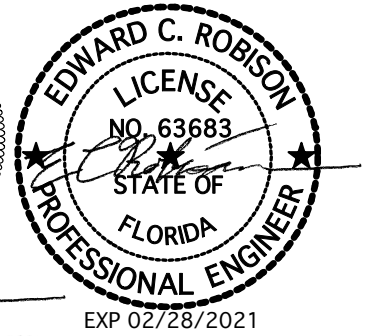
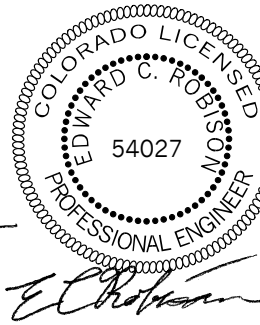
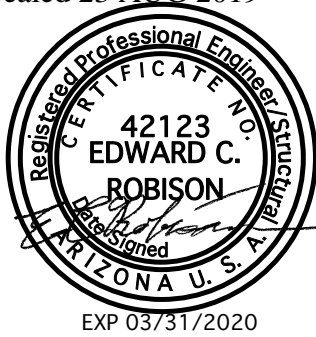

THIS WORK WAS PREPARED BY ME OR UNDER MY SUPERVISION

E. Robison 04/30/2020

Signature

Expiration Date of the License

EXP 11/30/2020

Professional Certification. I hereby certify that these documents were prepared or approved by me, and that I am a duly licensed professional engineer under the laws of the State of Maryland. License No. 52500, Expiration Date: 04/09/2020

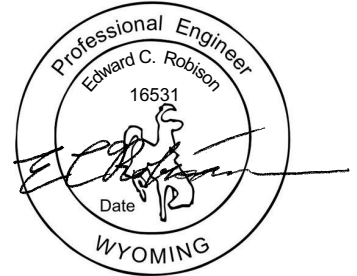
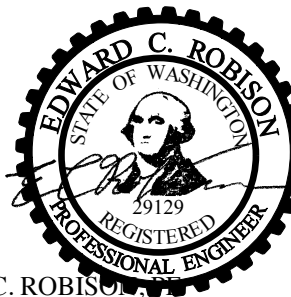
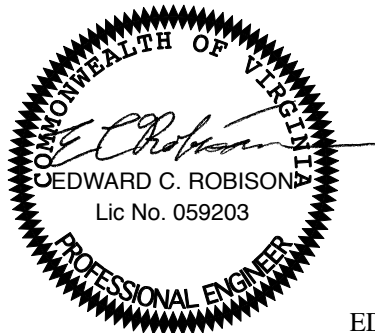
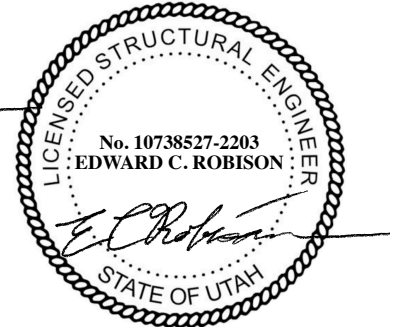
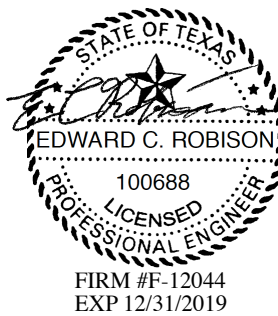
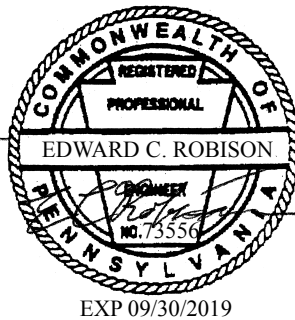
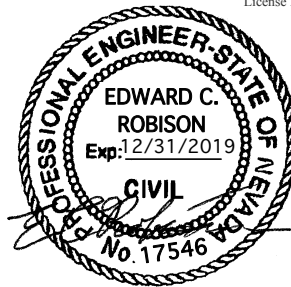
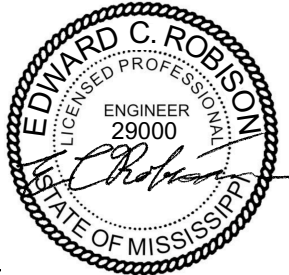
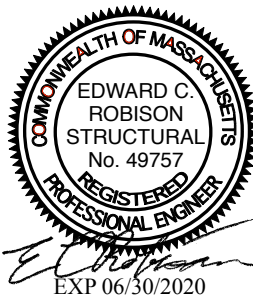

EDWARD C. ROBISON

10012 Creviston Dr NW
Gig Harbor, WA 98329

253-858-0855/Fax 253-858-0856 elrobison@narrows.com

Typical loads:

Load cases illustrated on Figure 1.

Live Loads:

50 plf load along glass at 42" above finish floor horizontal:

LOADS ON CLAMPS

V_c = shear load on clamp

M_c = Moment on clamp

$V_c = 50\text{plf} * S/2$

$M_c = 50\text{plf} * 42'' * S/2$

or

200 lb concentrated load at 42" above finish floor horizontal

$V_c = 200/C_c$ where

C_c from Figure 2

$M_c = V_c * 42''$

or

Wind load uniform load over entire glass light area. **Wind load must be determined by a competent professional for a specific installation.**

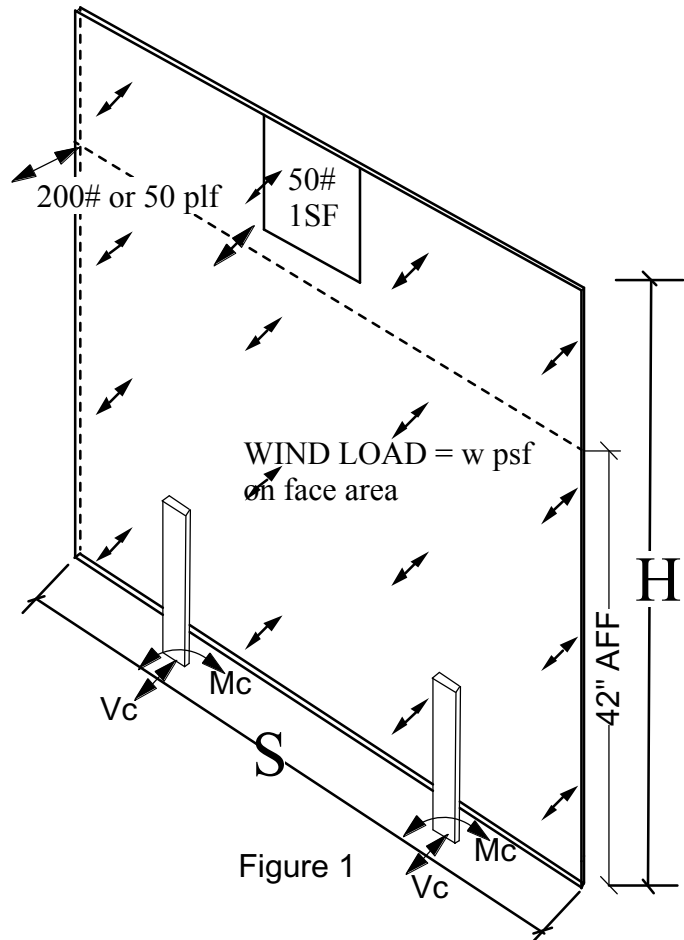

$V_c = w * H * S/2$

$M_c = V_c * H * 0.55$

Figure 2

All loads must be considered as acting inwards or outwards.

The clamp loads must be determined to verify that the allowable loads as shown in table 4 aren't exceeded.

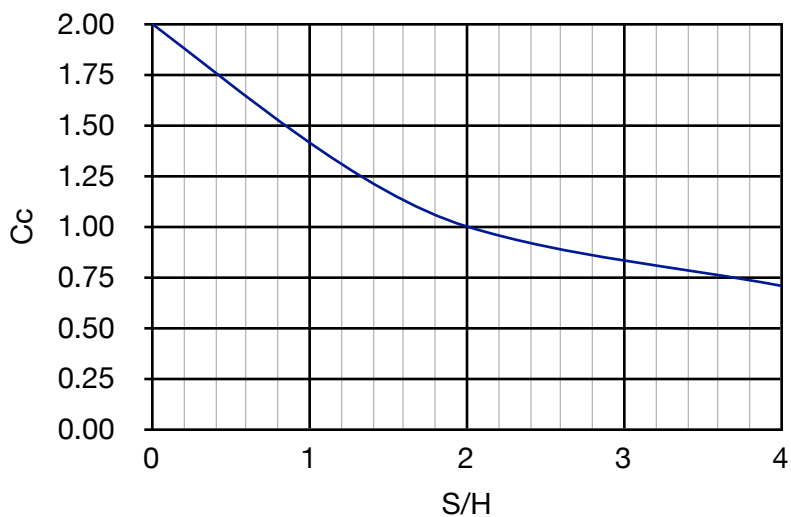

EDWARD C. ROBISON, PE

10012 Creviston Dr NW

Gig Harbor, WA 98329

253-858-0855/Fax 253-858-0856 elrobison@narrows.com

GLASS STRENGTH

All glass is fully tempered glass conforming to the specifications of ANSI Z97.1, ASTM C 1048-97b and CPSC 16 CFR 1201. The average Modulus of Rupture for the glass F_r is 24,000 psi. . In accordance with IBC 2407.1.1 glass used as structural balustrade panels shall be designed for a safety factor of 4.0. This is applicable only to structural panels (glass provides support to railing). Other locations the glass stress may be increased to as high as 10,600 psi edge stress in accordance with ASTM E1300-00.

Allowable glass bending stress: $24,000/4 = 6,000$ psi. – Tension stress calculated.

Allowable compression stress = $24,000\text{psi}/4 = 6,000$ psi.

Allowable bearing stress = $24,000$ psi/4 = 6,000 psi.

For wind loads only: allowable stress from ASTM E-1300 = 10,600 psi

Bending strength of glass for the given thickness:

$$S = \frac{12'' * (t_{\min})^2}{6} = 2 * (t_{\min})^2 \text{ in}^3/\text{ft}$$

For 1/2" glass $t_{\min} = 0.469''$; $t_{\text{ave}} = 0.50''$

$$S = 2 * (0.469)^2 = 0.44 \text{ in}^3/\text{ft}$$

$$M_{\text{allowable}} = 6,000\text{psi} * 0.44 \text{ in}^3/\text{ft} = 2,640''\#/ft = 220'\#/ft$$

For wind load case:

$$M_{\text{allowable}} = 10,600\text{psi} * 0.44 \text{ in}^3/\text{ft} = 4,664''\#/ft = 352'\#/ft$$

For 3/8" glass $t_{\min} = 0.355''$; $t_{\text{ave}} = 0.380''$

$$S = 2 * (0.355)^2 = 0.252 \text{ in}^3/\text{ft}$$

$$M_{\text{allowable}} = 6,000\text{psi} * 0.252 \text{ in}^3/\text{ft} = 1,512.3''\#/ft = 126.0'\#/ft$$

For wind load case:

$$M_{\text{allowable}} = 10,600\text{psi} * 0.252 \text{ in}^3/\text{ft} = 2,671''\#/ft = 222.6'\#/ft$$

Laminated glass sizes are covered further in this report.

EDWARD C. ROBISON, PE

10012 Creviston Dr NW

Gig Harbor, WA 98329

253-858-0855/Fax 253-858-0856 elrobison@narrows.com

Determine Glass Stresses:

The glass is subject to stress concentrations which are a function of the glass height and width. The stress concentrations were modeled using finite element analysis models- Models were prepared using SCIA Engineer 18. The stress concentration effects were normalized by dividing the peak model stress by the calculated average stress to develop the proposed design curves for determining the peak glass stress. Moment amplification factors vary greatly with glass width and vary slightly with glass height.

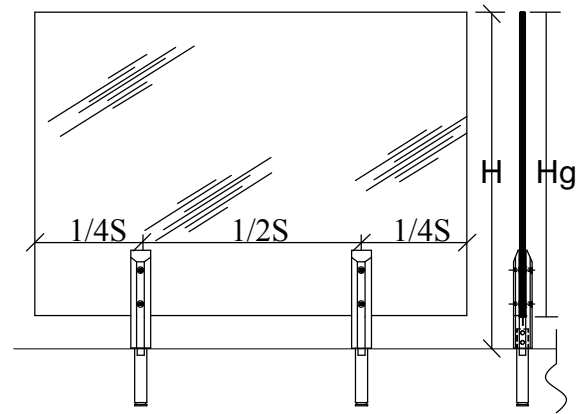

Figure 4

Linear interpolation for widths and heights between those shown may be used to determine the amplification factor (β).

Table 1: Moment Amplification Factor For Uniform Loading At Top of Glass based on glass light width and height

Glass Height (in)	Glass Width (in)				
	36	48	60	68	72
36	2.13	2.71	3.35	3.77	3.98
42	2.15	2.76	3.38	3.80	4.02
48	2.19	2.81	3.43	3.85	4.07
60	2.22	2.83	3.45	3.88	4.10

Table 2: Moment Amplification Factor For Uniform Wind Loading based on glass light width and height

Glass Height (in)	Glass Width (in)				
	36	48	60	68	72
36	1.98	2.53	3.15	3.55	3.75
42	2.01	2.60	3.20	3.61	3.81
48	2.07	2.67	3.27	3.68	3.89
60	2.12	2.72	3.32	3.74	3.95

To calculate the peak glass moment (in-lb per foot) the average bending moment is calculated based on a simple cantilever and then multiplied by the amplification factor β :

For 50 plf live load at 42" above finish floor or top of glass whichever is less:

$$M_{gL} = \beta * 50 \text{plf} * h \text{ or } = \beta * 50 \text{plf} * H_g$$

where $h = 42$ " minus height from walking surface to bottom of glass

50 lbs on one square foot concentrated load doesn't need to be checked if the 50 plf or 200 lb loads are checked. 50plf and 200 lb load cases only need to be checked if installation is required to provide fall protection or pool/spa fence. 50 lbs on one square foot concentrated load is the only live load check required when used as a wind screen only. Generally, the glass will be unable to hold the 200# concentrated live load except for shorter glass panels that are connected together. If the Frameless Windscreen System is to be used as a guard rail, then a qualified engineer must analyze live loading on the specific system.

For wind loads:

$$M_{gw} = \beta w H_g^2 * 0.55 / 12 \text{ (in-lb per foot) for } w \text{ in psf and } H_g \text{ in inches}$$

Peak Glass Stress:

$$f_{bg} = M / (2 * t_{\min}^2) \text{ in psi}$$

GLASS DEFLECTIONS

There is no building code defined limit on the glass deflections. ASTM E 2358 *Standard Specification for the Performance of Glass in Permanent Glass Railing Systems, Guards, and Balustrades* limits deflection to H/12 (ASTM E 6.2.1.1). ICC Acceptance Criteria AC 439 *Acceptance Criteria for Glass Railing and Balustrade Systems* (July 2015) Paragraph 3.3 applies a 1 inch deflection limit to the glass for the live load cases.

The finite element models were used to determine the deflection amplification caused by the reduced stiffness provided by the point supports using the clamps.

The deflection of glass may be estimated using the following equations:

For 50plf top rail loading:

$$\Delta = \lambda 50H_g^3 / (3 * 10.4 * 10^6 * t_{ave}^3)$$

For wind loading:

$$\Delta = \lambda PH_g^4 / (8 * 10.4 * 10^6 * t_{ave}^3)$$

λ = deflection amplification factor which is a function of the height and width and may be taken from the appropriate width curve in Figures 4 and 5.

Figure 4: Deflection Amplification Factor For 50plf Load

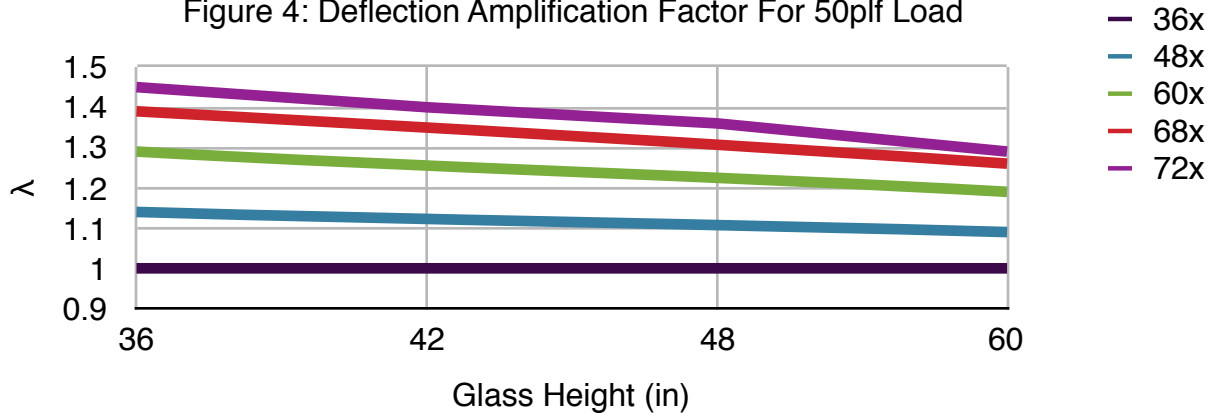
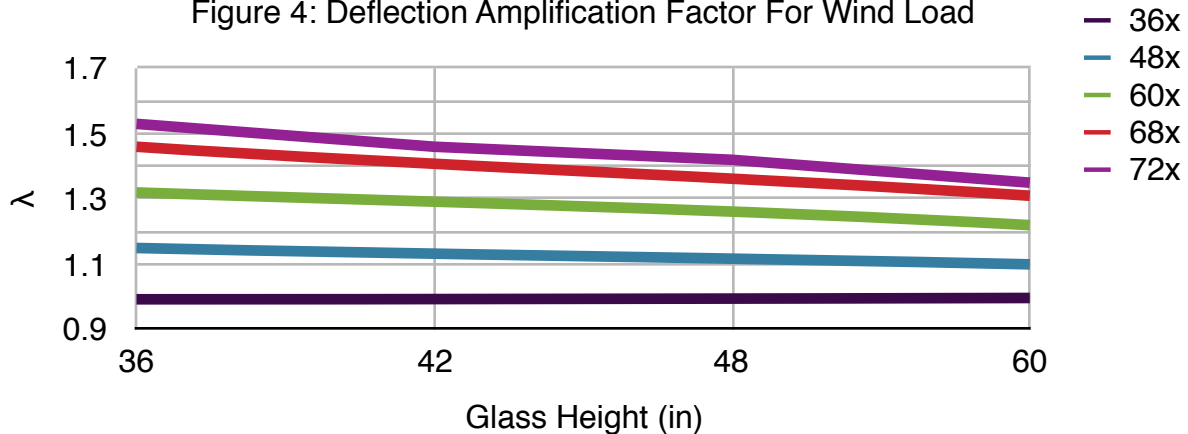

Figure 4: Deflection Amplification Factor For Wind Load



EDWARD C. ROBISON, PE
 10012 Creviston Dr NW
 Gig Harbor, WA 98329

253-858-0855/Fax 253-858-0856 elrobison@narrows.com

Table 3: Deflection Amplification Factor For Live Loading based on glass light width and height

Glass Height (in)	Glass Width (in)				
	36	48	60	68	72
36	1.00	1.14	1.29	1.39	1.45
42	1.00	1.12	1.25	1.35	1.40
48	1.00	1.11	1.23	1.31	1.36
60	1.00	1.09	1.19	1.26	1.29

Table 4: Moment Amplification Factor For Uniform Wind Loading based on glass light width and height

Glass Height (in)	Glass Width (in)				
	36	48	60	68	72
36	0.993	1.15	1.32	1.46	1.53
42	0.993	1.13	1.29	1.40	1.46
48	0.995	1.12	1.27	1.37	1.42
60	0.997	1.10	1.22	1.31	1.35

Allowable wind loads on the wind screen are a function of the glass light height and width. The allowable wind load may be calculated from:

$$w_{\text{all}} = M_{\text{all}} * 12 / (\beta H_g^2 * 0.55) = 462545 t_{\text{min}}^2 / (\beta H_g^2)$$

(derived from the equations on page 5)

Or taken from Tables 5 or 6.

Table 5 & 6: Allowable Uniform Wind Loading based on glass light width and height**1/2" Monolithic Tempered Glass - $t_{min} = 0.469"$**

Glass Height (in)		Glass Width (in)			
	36	48	60	68	72
36	39.6	31.0	24.9	22.1	20.9
42	28.7	22.2	18.0	16.0	15.1
48	21.3	16.5	13.5	12.0	11.4
60	13.3	10.4	8.5	7.6	7.2

3/8" Monolithic Tempered Glass - $t_{min} = 0.355"$

Glass Height (in)		Glass Width (in)			
	36	48	60	68	72
36	22.7	17.8	14.3	12.7	12.0
42	16.4	12.7	10.3	9.2	8.7
48	12.2	9.5	7.7	6.9	6.5
60	7.6	6.0	4.9	4.3	4.1

Linear interpolation between the dimensions shown may be used.

The wind loads for a specific installation shall be determined by a qualified professional considering wind speed, exposure, terrain, location on structure, use and other applicable factors.

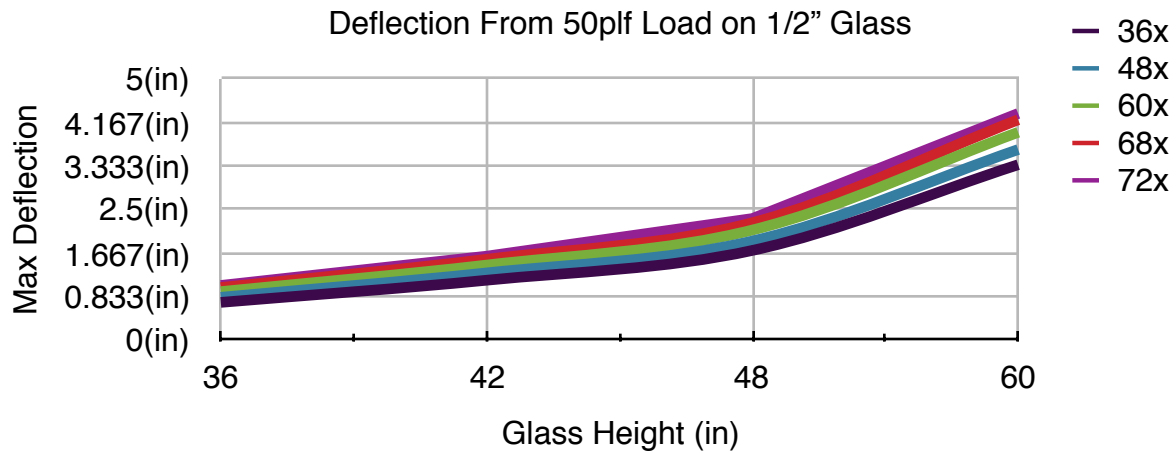

Table 7
Deflection From 50plf Load on 1/2" Monolithic Tempered Glass - $t_{min} = 0.469"$

Glass Height (in)	Glass Width (in)				
	36	48	60	68	72
36	0.7	0.8	0.9	1.0	1.1
42	1.2	1.3	1.4	1.6	1.6
48	1.7	1.9	2.1	2.3	2.3
60	3.4	3.7	4.0	4.2	4.3

FOR FALL PROTECTION:

Table 8
1/2" Monolithic Tempered Glass - $t_{min} = 0.469"$

Glass must be installed with a continuous structural top rail, $I_y \geq 0.1 \text{ in}^4$ for stainless steel or 0.29 in^4 for aluminum.

Glass Height (in)	Glass Width (in)			
	36	42	48	54
33	OK	OK	OK	OK
36	OK	OK	OK	NO
39	OK	OK	NO	NO
42	OK	NO	NO	NO

The top rail must have alternative supports at the end attached to a wall or post.

LAMINATED GLASS:

Laminated tempered glass may be used with the glass clamps. The effective thickness of the laminated glass may be determined per ASTM E1300-12a appendix X9. For determining the effective glass thickness use the lesser of the glass width or glass height. Typically the laminated glass is fabricated with 0.06" interlayer of either PVB or Kuraray SentryGlas+® ionoplast interlayer. Table 9 may be used to select the effective glass thickness for 7/16" and 9/16" laminated glass made with either PVB or SGP evaluated at 120°F.

Table 9 - Effective Thickness of Laminated Glass:

	PVB				SGP (psi)		
G	70				1638.9		
	$h_1 = h_2$	h_v		$h_{s;1} = h_{s;2}$		I_s	h_s
3/16"	0.18	0.06		0.12		0.005184	0.24
1/4"	0.219	0.06		0.1395		0.0085235	0.279
	Shortest Dimension	Γ PVB	Γ SGP	$h_{ef;w}$ PVB	$h_{ef;w}$ SGP	$h_{1;ef;\sigma}$ PVB	$h_{1;ef;\sigma}$ SGP
3/16+0.06+3/16 = 7/16" Laminated Glass	36	0.144	0.798	0.274	0.394	0.310	0.406
	42	0.186	0.843	0.285	0.400	0.322	0.409
	48	0.230	0.875	0.296	0.404	0.332	0.412
	54	0.275	0.899	0.306	0.407	0.342	0.413
	60	0.319	0.916	0.316	0.409	0.350	0.414
1/4"x0.06"x1/4" = 9/16" Laminated Glass	36	0.121	0.764	0.322	0.463	0.364	0.479
	42	0.158	0.815	0.334	0.471	0.376	0.484
	48	0.197	0.852	0.345	0.476	0.388	0.487
	54	0.237	0.879	0.356	0.481	0.398	0.489
	60	0.278	0.900	0.367	0.484	0.408	0.490

$h_{ef;w}$ = effective glass thickness for deflections

$h_{1;ef;\sigma}$ = effective glass thickness for bending stress

EDWARD C. ROBISON, PE

10012 Creviston Dr NW

Gig Harbor, WA 98329

253-858-0855/Fax 253-858-0856 elrobison@narrows.com

Table 10 - 13: Allowable Uniform Wind Loading based on glass light width and height**Table 10****9/16" PVB Laminated Tempered Glass - $t_{min} = 0.364"$**

Glass Height (in)		Glass Width (in)			
	36	48	60	68	72
36	23.9	18.7	15.0	13.3	12.6
42	17.3	13.4	10.9	9.6	9.1
48	12.9	10.0	8.1	7.2	6.8
60	8.0	6.3	5.1	4.6	4.3

Table 11**7/16" PVB Laminated Tempered Glass - $t_{min} = 0.310"$**

Glass Height (in)		Glass Width (in)			
	36	48	60	68	72
36	17.3	13.6	10.9	9.7	9.1
42	12.5	9.7	7.9	7.0	6.6
48	9.3	7.2	5.9	5.2	5.0
60	5.8	4.5	3.7	3.3	3.1

Table 12**9/16" SGP Laminated Tempered Glass - $t_{min} = 0.479"$**

Glass Height (in)		Glass Width (in)			
	36	48	60	68	72
36	41.4	32.4	26.0	23.1	21.8
42	29.9	23.1	18.8	16.7	15.8
48	22.3	17.3	14.1	12.5	11.8
60	13.9	10.8	8.9	7.9	7.5

Table 13**7/16" SGP Laminated Tempered Glass - $t_{min} = 0.406"$**

Glass Height (in)		Glass Width (in)			
	36	48	60	68	72
36	29.7	23.3	18.7	16.6	15.7
42	21.5	16.6	13.5	12.0	11.3
48	16.0	12.4	10.1	9.0	8.5
60	10.0	7.8	6.4	5.7	5.4

FOR FALL PROTECTION:**Table 14****9/16" SGP Laminated Tempered Glass - $t_{min} = 0.479"$**

Glass must be installed with a continuous top rail or corners clamped together and the joint fully butt glazed with structural silicone.

Glass Height (in)		Glass Width (in)		
	36	48	60	68
33	OK	OK	OK	OK
36	OK	OK	OK	NO
39	OK	OK	NO	NO
42	OK	NO	NO	NO

The top rail or end lights must have alternative supports at the end attached to a wall or post.

The glass height is the measured from bottom to top of glass and not height above the walking surface.

GLASS CLAMPS

The glass clamp is composed of an adjustable clamping system which is made up of stainless steel clamp bodies (either cast or wrought depending on style), 5/16” diameter screws through the glass, and gaskets with varying thicknesses to accommodate selected glass thickness. The clamp varies in height by style but all styles have a similar glass bite. Various clamps are available for installation on substrates of concrete, metal and wood and attachment to the surface or fascia.

The CRL clamps require either one or two 3/4” holes through the glass at each clamp depending on the specific style. The holes are used to tie the clamp bodies together through the glass to provide the clamping force and develop the full clamp strength. Where indicated herein some styles of clamps may be used without the glass hole at a reduced clamp strength.

The maximum allowable moment on the clamps shall not exceed the moments indicated herein.

Available clamp styles covered in this report

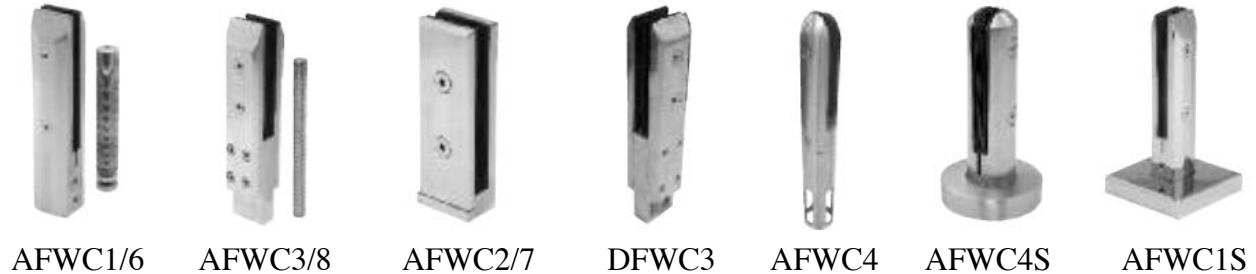

The Friction Fit Clamps are intended for installations without holes through the glass. These clamps don't have a through glass bolting option and are intended for locations with lesser wind loads or small light sizes and where fall protection typically isn't required.



AFWC1/AFWC6

One Piece Post Option: 316 Stainless Steel casting with glass pocket mounted on 1-3/16" (30mm) stainless steel rod core mounted into concrete.

Check bending strength of bar:
Based on AISC Design Guide 27:

$$Z = d^3/6 = 1.181^3/6 = 0.2746 \text{ in}^3$$

Wrought 316 stainless steel bars

$$F_y \geq 50 \text{ ksi and } F_u \geq 75 \text{ ksi}$$

$$M_n = 0.2746 * 50 \text{ ksi} = 13,730 \text{ #"}$$

$$M_s = M_n / 1.67$$

$$M_s = 13,730 \text{ #"} / 1.67$$

$$M_s = 8,222 \text{ #"}$$

Determine strength of anchorage into concrete:

Moment is resisted by vertical compression against the concrete by the embedded rod. The grooves on the end of the rod prevent withdrawal.

From ΣM about centroid of C_1 :

$$M_n = C_1 * D(2/3)$$

$$C_u = \phi F_B$$

F_B = shear block failure from ACI 318 App D.6.2

$$F_B = 1.4 * \sqrt{1.5 * 7} (6 / 1.181)^{0.2} (1.181 * 2500)^{1/2} * 6^{1.5} = 13,267 \text{ #}$$

$$C_u = 0.85 * 13,267 \text{ #} = 11,277 \text{ #}$$

$$M_n = 11,277 \text{ #} * 6 * (2/3) = 45,108 \text{ #"}$$

$$M_s = 0.70 * 45,108 / 1.6 = 19,735 \text{ #"}$$

Minimum embed depth of 4.5"

$$F_B = 1.4 * \sqrt{1.5 * 7} (4.5 / 1.181)^{0.2} (1.181 * 2500)^{1/2} * 4.5^{1.5} = 8,135 \text{ #}$$

$$C_u = 0.85 * 8,135 \text{ #} = 6,915 \text{ #}$$

$$M_n = 6,915 \text{ #} * 4.5 * (2/3) = 20,745 \text{ #"}$$

$$M_s = 0.70 * 20,745 / 1.6 = 9,076 \text{ #"}$$

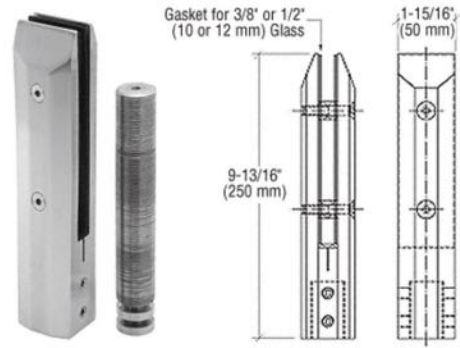

EDWARD C. ROBISON, PE

10012 Creviston Dr NW

Gig Harbor, WA 98329

253-858-0855/Fax 253-858-0856 elrobison@narrows.com

Check strength of clamp glass pocket.

Glass to clamp moment resisted by tension in cap screws:

Screw tension is proportional to distance from bottom screw to screw being considered:

5/16" diameter cap screws upper two.

Screw tension strength - ASTM F 879

$T = 3,980\#$ (ASTM F 879 Table 3)

$T_a = 3,980/2 = 1,990\#$

Moment resistance M_a

$M_a = 1,990\#*(5.625''+3.6875''^2/5.625'') = 16,004''\# \geq 8,222''\#$

ALLOWABLE DESIGN MOMENT = 8,222''# WITH BOLTS THROUGH GLASS

For installations without bolts through glass:

Check for bending of side plates:

$S = 0.160 \text{ in}^3$

$F_y = 30 \text{ ksi}$ for cast 316 Stainless steel

$M_n = ZF_y = 0.160*30 \text{ ksi} = 4,800 \text{ ''}\#$

$M_a = 4,800/1.67 = 2,874''\#$

ALLOWABLE DESIGN MOMENT = 2,874''# WITHOUT BOLTS THROUGH GLASS

EDWARD C. ROBISON, PE

10012 Creviston Dr NW

Gig Harbor, WA 98329

253-858-0855/Fax 253-858-0856 elrobison@narrows.com

AFWC2/7

CRL Two-Piece Side Mount Frameless Windscreen Clamp

new

- 316 Grade Stainless Steel in Two Architectural Finishes
- Great for Windscreens or Glass Partitions (Not Designed for Guard Rail Applications)
- For 3/8" or 1/2" (10 or 12 mm) Tempered Monolithic Glass and 9/16" (13.52 mm) Tempered Laminated Glass

CRL Two-Piece Side Mount Frameless Windscreen Clamps are designed for attachment to the front side of walls or planter boxes. Due to the number of varying mounting conditions, anchors and mounting screws are not supplied. The back plate is fabricated to accept 8 mm (5/16") flat head screws. Glass fabrication requires two 3/4" (19 mm) holes per Clamp. An instruction sheet and glass fabrication template are supplied.

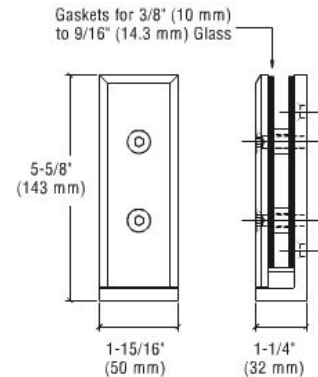

CAT. NO.	FINISH
AFWC2	Brushed Stainless
AFWC7	Polished Stainless

Minimum order: 1 each.

Clamp is mounted to a deck edge, beam web or wall face to support the glass light. Clamp may be installed to concrete, steel or other metal or wood. Clamp body is attached to the supporting structure using two 5/16" dia countersunk screws.

For anchorage to steel use two countersunk stainless steel screws:

Screw tension strength - ASTM F 879

$$T = 3,980\# \text{ (ASTM F 879 Table 3)}$$

$$T_a = 3,980/2 = 1,990\#$$

$$V_a = 0.6 * 1990 = 1194\#$$

Moment strength of anchorage to steel:

$$M_s = 1,990\# * 4.75" = 9453" \#$$

$$V_s = 0.2 * 2 * 1194 = 478\#$$

For anchorage to concrete - Assumed conditions:

Minimum concrete strength $f'c = 3,000$ psi

Minimum concrete edge distance = 1.75"

Alternative anchorage may be designed for specific project conditions.

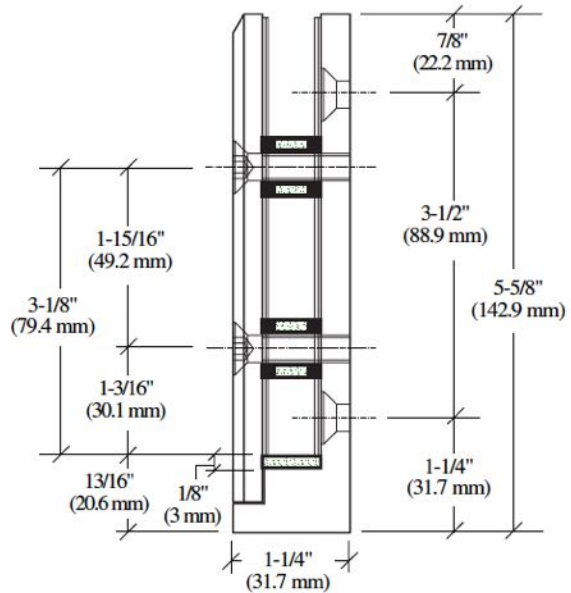

For anchorage to concrete using two 1/4" x 2-1/2" Tapcon screws with 1.75" effective embedment:

$$T_a = 550\# \text{ (ITW Red Head technical information)}$$

$$V_a = 420\#$$

$$M_s = 550 * 4.75" = 2,613" \#$$

$$V_s = 0.2 * 2 * 420 = 168\#$$

EDWARD C. ROBISON, PE

10012 Creviston Dr NW

Gig Harbor, WA 98329

253-858-0855/Fax 253-858-0856 elrobison@narrows.com

For 1/4" countersunk screw into Red Head Multi-Set II Drop-In Anchor

$T_a = 590\#$ (ITW Red Head technical information)

$V_a = 270\#$

$M_s = 590 * 4.75" = 2,803\#\text{'}$

$V_s = 0.2 * 2 * 270 = 108\#$

For wood:

5/16" x 4" wood screw into wood with $G \geq 0.46$

Assumes installation is in location where wood moisture content remains below 19%

Withdrawal strength of screw from National Design Specification for Wood Construction 11.2.2:

$W = 2850G^2D = 2850 * 0.46^2 * 0.3125 = 180 \text{ pli}$

$W' = C_D W e$

$C_D = 1.6$ for wind loads

$e = 3 \frac{1}{8}"$

$W' = 1.6 * 180 \text{ pli} * 3.125" = 900\#$

Shear strength based on NDS 11.3.1

$Z_{\perp} = 170\#$

$Z'_{\perp} = C_D Z_{\perp} = 1.6 * 170\# = 272\#$

Combined lateral and withdrawal loads (NDS Table 11.4)

$Z'_{\perp} = (W'Z') / [W' \cos^2 \alpha + Z' \sin^2 \alpha]$

For assumed dead load of 78# on bracket (39# on screw) and $W = 700\#$

$\alpha = \tan^{-1}(700/39) = 86.8^\circ$ resultant = $\sqrt{(700^2 + 39^2)} = 702\#$

$Z'_{\perp} = (900 * 272) / [900 \cos^2 86.8^\circ + 272 \sin^2 86.8^\circ] = 894\#$

Screw withdrawal strength may be increased to 890# for maximum light size:

$M_s = 890 * 4.75" = 4,228\#\text{'}$

$V_s = 2 * 39 = 78\#$ dead load

When attached to wood subject to wetting where moisture content will exceed 19% at any time after installation then the allowable loads are to be multiplied by $C_M = 0.7$.

EDWARD C. ROBISON, PE

10012 Creviston Dr NW

Gig Harbor, WA 98329

253-858-0855/Fax 253-858-0856 elrobison@narrows.com

AFWC3/8**Three Piece Core Mount Frameless Windscreen Clamp**

Post is attached to 5/8" (16mm) rod set into concrete and grouted to base of side bars. For full clamp strength grout must be to base of side plates

Determine strength of anchorage into concrete:

Moment is resisted by a combination of vertical compression against concrete with tension in the anchor rod and by bending of center plate which is anchored by horizontal compression against concrete.

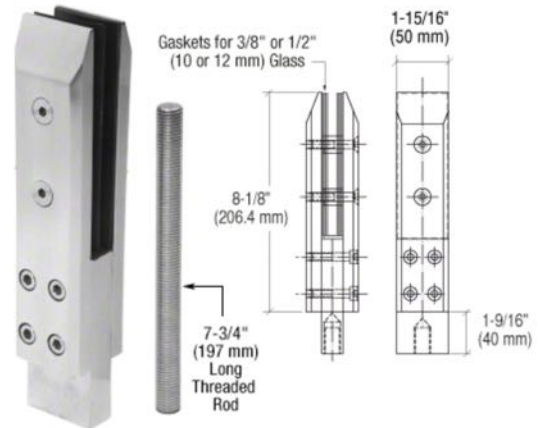

Nominal strength of vertical compression of side plate against concrete:

$\phi F_B = \phi \beta f'_c$ where:

$$\beta = \sqrt{A_2/A_1} = \sqrt{16/(1/2 \times 1 \ 15/16)} \text{ but } \leq 2.0$$

and $f'_c = 6$ ksi for specified anchoring grout

$$\phi F_B = 0.85 \times 2 \times 6,000 = 10,200 \text{ psi}$$

$$C_{pn} = 0.5 \times 1.9375 \times 10,200 \text{ psi} = 9,881 \#$$

Bar tension strength, nominal

$$F_y = 75 \text{ ksi (1/4 hard A316)}$$

$$T_b = 0.195 \text{ in}^2 \times 75 \text{ ksi} = 14,625 \#$$

C_{pn} controls

$$M_{C_{pn}} = 0.6875 \times 9,881 \# = 6,793 \#$$

Nominal strength from bending of center flat bar

Bar bending:

$$Z = 1.9375 \times 0.9375^2 / 4 = 0.4257 \text{ in}^3$$

$$F_y = 45 \text{ ksi}$$

$$M_{pn} = 45 \text{ ksi} \times 0.425 \text{ in}^3 = 19,157 \#$$

Check anchorage:

Center plate is anchored into concrete:

V_n = shear strength of bar

$$V_n = A \times F_{yv} = 0.195 \times 42 \text{ ksi} = 8,190 \#$$

Allowable shear in bar must be reduced for tension:

$$1 \geq (T/T_n)^2 + (V/V_n)^2$$

$$V_b = V_n [1 - (T/T_n)^2] = 8190 \# [1 - (9881 \# / 14625 \#)^2] = 4,452 \#$$

Check anchor strength of bar:

EDWARD C. ROBISON, PE

10012 Creviston Dr NW

Gig Harbor, WA 98329

253-858-0855/Fax 253-858-0856 elrobison@narrows.com

$$C_u = V_b + C_1 \text{ and } V_b = C_1$$

$$C_u = 2 * 4,452\# = 8,904\#$$

Bearing length along bar for:

$$F_{BC} = 10,200 \text{ psi}$$

$$L = [C_u / (d_b F_{BC})] / 0.85$$

$$L = [8,904\# / (1/2'' * 10,200 \text{ psi})] / 0.85 = 2.05'' < 4'' \text{ Bar length is adequate}$$

Determine C_c

Maximum value for C_c if in full compression:

$$C = 1.56'' * 1.9375'' * 10,200 \text{ psi} * 0.85 = 26,205\# > V_b$$

C_c must be balanced with V_b and C_b

a = compression depth for C_c

$$C_b + V_b = C_c \text{ and}$$

$$C_b = (1.56'' - a) * 1.9375'' * 10,200 \text{ psi}$$

$$C_c = a * 1.9375'' * 10,200 \text{ psi}$$

substituting into above and solving for a :

$$(1.56'' - a) * 1.9375'' * 10,200 \text{ psi} + 4,452\# = 1.9375'' * 10,200 \text{ psi} * a$$

$$(1.56'' - a) * 0.2253'' = a$$

$$1.79'' = 2a$$

$$0.89'' = a$$

Calculate C_c from a

$$C_c = 0.89'' * 1.9375'' * 10,200 \text{ psi} = 17,589\#$$

$$C_b = 17,589 - 4,452 = 13,137\#$$

Calculate the resisted moment by ΣM about C_c

$$M_{h_n} = (1.56'' - 0.89/2) * 4,452 + (1.56''/2 - 0.89''/2) * 13,137 = 9,365\#''$$

The total nominal moment strength of the anchorage:

$$M_n = M_{h_n} + M_{c_{pn}} = 9,365\#'' + 6,793\#'' = 16,158\#''$$

$$M_s = \phi M_n / 1.6 = 0.75 * 16,158\#'' / 1.6 = 7,574\#''$$

Allowable service moment based on clamp anchorage = 7,574#''

Minimum embed depth of rod into concrete = $3 * 1.9375 = 5.81$ - Use 6'' minimum

Minimum slab thickness at embed = $1.5 * 6'' = 9''$

Minimum slab thickness required for 1' radius or 6'' radius if slab thickness is 12'' minimum.

EDWARD C. ROBISON, PE

10012 Creviston Dr NW

Gig Harbor, WA 98329

253-858-0855/Fax 253-858-0856 elrobison@narrows.com

Check moment strength of clamp

Glass to bracket moment resisted by tension in cap screws:

Screw tension is proportional to distance from bottom screw to screw being considered:

5/16" diameter cap screws upper two.

1/4" diameter cap screws for lower four.

$T_{5/16} = 3,980\#$ (ASTM F 879 Table 3)

$T_{1/4} = 2,703\#$ (ASTM F 879 Table 3)

Moment resistance M_n

$$M_n = 3,980\#*(5.625''+3.6875''^2/5.625'')+2,420\#*(1.375''^2/5.625'')*2$$

$$M_n = 33,635$$

$$M_s = 33,635/2.0 = 16,818\#''$$

Check for bending of side bars:

$$Z = 1.75''*0.5625^2/4 = 0.1384 \text{ in}^3 \text{ (effective dimensions)}$$

$$F_y = 30 \text{ ksi}$$

$$M_n = 0.1384*30 \text{ ksi} = 4,153$$

$$M_s = 4,153/1.67 = 2,487\#''$$

Moment Strength of fully installed clamp:

$$M_s = 2*2,487 = 4,974$$

ALLOWABLE DESIGN MOMENT = 4,974" # WITH BOLTS THROUGH GLASS

ALLOWABLE DESIGN MOMENT = 2,487" # WITHOUT BOLTS THROUGH GLASS

EDWARD C. ROBISON, PE

10012 Creviston Dr NW

Gig Harbor, WA 98329

253-858-0855/Fax 253-858-0856 elrobison@narrows.com

DFWC3**CRL Three-Piece Core Mount Clamp**

- Made of Duplex 2205 Grade Brushed Stainless Steel
- Designed for 3/8" or 1/2" (10 or 12 mm) Tempered Monolithic Glass and 9/16" (13.52 mm) Tempered Laminated Glass

Duplex 2205 is a more corrosive-resistant, higher grade of stainless steel than #316. It is ideally suited for areas within 1 kilometer of saltwater environments due to higher chromium content in the metal. Glass fabrication required two 19 mm (3/4") holes per clamp.

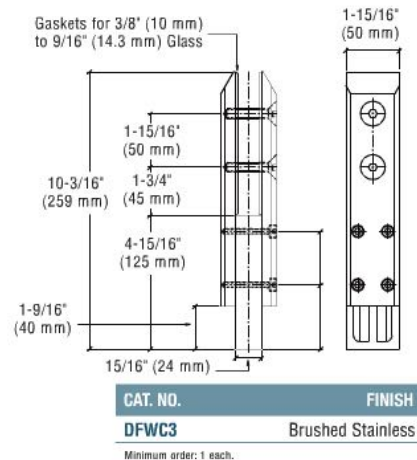

Clamp anchorage strength is same as calculated for the AFCW3 clamp.

Check moment strength of clamp

Glass to bracket moment resisted by tension in cap screws:

Screw tension is proportional to distance from bottom screw to screw being considered:

5/16" diameter cap screws upper two.

1/4" diameter cap screws for lower four.

$T_{5/16} = 3,980\#$ (ASTM F 879 Table 3)

$T_{1/4} = 2,703\#$ (ASTM F 879 Table 3)

Moment resistance M_n

$$M_n = 3,980\# \cdot (5.062'' + 3.125''^2 / 5.062'') + 2,420\# \cdot (1.375''^2 / 5.062'') \cdot 2$$

$$M_n = 29,635$$

$$M_s = 29,635 / 2.0 = 14,817\#''$$

Check for bending of side bars:

$$Z = 1.75'' \cdot 0.5625^2 / 4 = 0.1384 \text{ in}^3 \text{ (effective dimensions)}$$

$$F_y = 45 \text{ ksi}$$

$$M_n = 0.1384 \cdot 45 \text{ ksi} = 6,228$$

$$M_s = 6,228 / 1.67 = 3,729\#''$$

Moment Strength of fully installed clamp:

$$M_s = 2 \cdot 3,729 = 7,458$$

ALLOWABLE DESIGN MOMENT = 7,458" # WITH BOLTS THROUGH GLASS

ALLOWABLE DESIGN MOMENT = 3,729" # WITHOUT BOLTS THROUGH GLASS

EDWARD C. ROBISON, PE

10012 Creviston Dr NW

Gig Harbor, WA 98329

253-858-0855/Fax 253-858-0856 elrobison@narrows.com

AFWC4

CRL Two-Piece Core Mount Round Clamp

- **Made of Duplex 2205 Grade Brushed Stainless Steel**
- **Designed for 3/8" or 1/2" (10 or 12 mm) Tempered Monolithic Glass and 9/16" (13.52 mm) Tempered Laminated Glass**

Duplex 2205 is a more corrosive-resistant, higher grade of stainless steel than #316. It is ideally suited for areas within 1 kilometer of saltwater environments due to higher chromium content in the metal. Glass fabrication requires one 19 mm (3/4") hole per clamp.

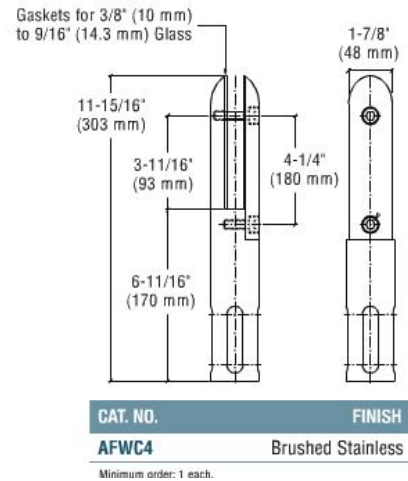

Clamp must be installed with bolt through the glass.

Strength of clamp anchorage into hole in concrete is similar to AFWC1 and won't control clamp strength.

Check moment strength of clamp:

Glass to clamp moment resisted by tension in cap screws:

Screw tension is proportional to distance from bottom screw to screw being considered:

5/16" diameter cap screws connectig side plate to main clamp body
 $T_{5/16} = 3,980\#$ (ASTM F 879 Table 3)

Moment resistance M_n

$$M_n = 3,980\# * 4.25''$$

$$M_n = 16,915''\#$$

$$M_s = 16,915/2.0 = 8,458''\#$$

Check for bending of side bars:

$$Z = 0.083 \text{ in}^3 \text{ (effective dimensions)}$$

$$F_y = 60 \text{ ksi For cast Duplex 2205}$$

$$M_n = 0.083 * 60 \text{ ksi} = 4,980$$

$$M_s = 4,980/1.67 = 2,982''\#$$

Moment Strength of fully installed clamp:

$$M_s = 2 * 2,982 = 5,964''\#$$

ALLOWABLE DESIGN MOMENT = 5,964''# WITH BOLTS THROUGH GLASS

AFWC1S

One piece surface mounted clamp. Clamp body is similar to the AFWC1 clamp.

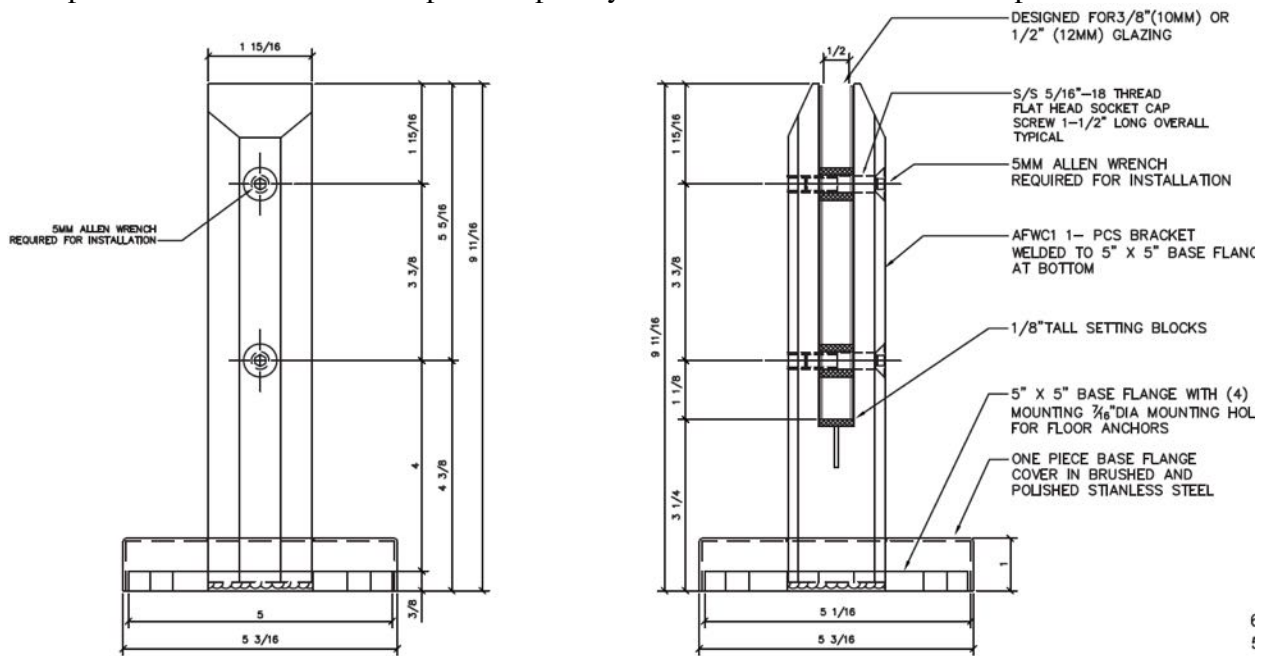

Check strength of clamp:

Glass to clamp moment resisted by tension in cap screws:

Screw tension is proportional to distance from bottom screw to screw being considered:

5/16" diameter cap screws upper two.

Screw tension strength - ASTM F 879

$$T = 3,980\# \text{ (ASTM F 879 Table 3)}$$

$$T_a = 3,980/2 = 1,990\#$$

Moment resistance M_a

$$M_a = 1,990\# * (4.5" + 1.125" / 2) = 9,515" \#$$

For installations without bolts through glass:

Check for bending of side plates:

$$S = 0.160 \text{ in}^3$$

$$F_y = 30 \text{ ksi for cast 316 Stainless steel}$$

$$M_n = ZF_y = 0.160 * 30 \text{ ksi} = 4,800 \text{ " \#}$$

$$M_a = 4,800 / 1.67 = 2,874 \text{ " \#}$$

EDWARD C. ROBISON, PE

10012 Creviston Dr NW

Gig Harbor, WA 98329

253-858-0855/Fax 253-858-0856 elrobison@narrows.com

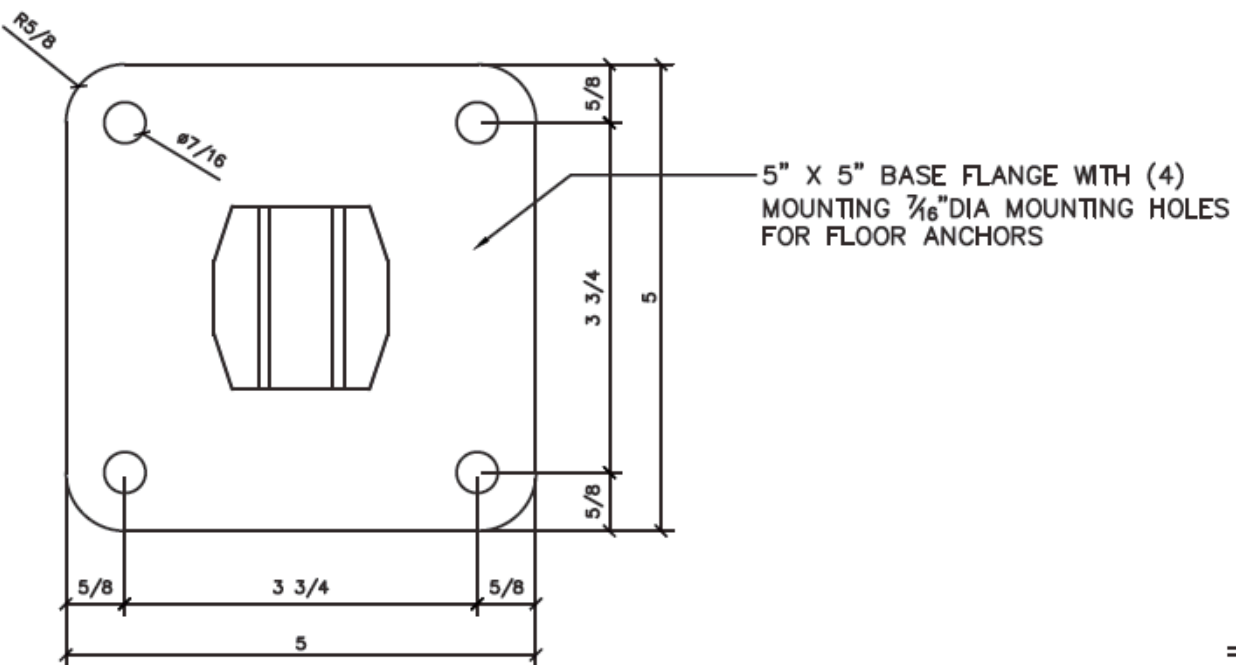
**CONNECTION TO STEEL:**

3/8" SS Bolts to steel framing with sufficient strength to properly support the imposed loads-
Tension strength of 3/8" bolts (ASTM F 593)

$$T_n = 0.0775 \text{ in}^2 * 70 \text{ ksi} = 5,425 \#$$

$$T_s = 5,425 \# / 2 = 2,713 \#$$

Allowable moment based on anchor strength:

$$M_s = 2 * 2,713 \# * 3.75" = 20,344" \#$$

BASE PLATE MOUNTED TO CONCRETE - Expansion Bolt Alternative:

Base plate mounted to concrete with ITW Red Head Trubolt wedge anchor 3/8"x3.75" concrete anchors with 3" effective embedment. Anchor strength based on ESR-2427

Minimum conditions used for the calculations:

$$f'_c \geq 3,000 \text{ psi}; \text{ edge distance} = 2.25" \quad \text{spacing} = 3.75"$$

$$h = 3.0": \text{ embed depth}$$

For concrete breakout strength:

$$N_{cb} = [A_{Ncg} / A_{Nco}] \phi_{ed,N} \phi_{c,N} \phi_{cp,N} N_b$$

$$A_{Ncg} = (1.5 * 3 * 2 + 3.75) * (1.5 * 3 + 2.25) = 86.06 \text{ in}^2 \quad 2 \text{ anchors}$$

$$A_{Nco} = 9 * 3^2 = 81 \text{ in}^2$$

$$C_{a,min} = 1.5" \quad (\text{ESR-2427 Table 3})$$

$$C_{ac} = 5.25" \quad (\text{ESR-2427 Table 3})$$

$$\phi_{ed,N} = 1.0$$

$$\phi_{c,N} = (\text{use } 1.0 \text{ in calculations with } k = 24)$$

$$\phi_{cp,N} = \max(1.5/5.25 \text{ or } 1.5 * 3 / 5.25) = 0.857 \quad (C_{a,min} \leq C_{ac})$$

$$N_b = 24 * 1.0 * \sqrt{3000} * 3.0^{1.5} = 6,830 \#$$

EDWARD C. ROBISON, PE

10012 Creviston Dr NW

Gig Harbor, WA 98329

253-858-0855/Fax 253-858-0856 elrobison@narrows.com

$$N_{cb} = 86.06/81 * 1.0 * 1.0 * 0.857 * 6,830 = 6,219 \leq 2 * 4,200$$

based on concrete breakout strength.

Determine allowable tension load on anchor pair

$$T_s = 0.65 * 6,219 \# / 1.6 = 2,526 \#$$

Check shear strength - Concrete breakout strength in shear:

$$V_{cb} = A_{vc} / A_{vco} (\phi_{ed,v} \phi_{c,v} \phi_{h,v} V_b)$$

$$A_{vc} = (1.5 * 3 * 2 + 3.75) * (2.25 * 1.5) = 43.03$$

$$A_{vco} = 4.5 (c_{a1})^2 = 4.5 (3)^2 = 40.5$$

$$\phi_{ed,v} = 1.0 \text{ (affected by only one edge)}$$

$$\phi_{c,v} = 1.4 \text{ uncracked concrete}$$

$$\phi_{h,v} = \sqrt{(1.5 c_{a1} / h_a)} = \sqrt{(1.5 * 3 / 3)} = 1.225$$

$$V_b = [7 (l_e / d_a)^{0.2} \sqrt{d_a}] \lambda \sqrt{f'_c} (c_{a1})^{1.5} = [7 (1.625 / 0.375)^{0.2} \sqrt{0.375}] 1.0 \sqrt{3000} (3.0)^{1.5} = 1,636 \#$$

$$V_{cb} = 43.03 / 40.5 * 1.0 * 1.4 * 1.225 * 1,636 \# = 2,981 \#$$

$$\text{Steel shear strength} = 1,830 \# * 2 = 3,660$$

Allowable shear strength

$$\phi V_N / 1.6 = 0.70 * 2,981 \# / 1.6 = 1,304 \#$$

$$\text{Shear load} = 250 / 1,304 = 0.19 \leq 0.2$$

Therefore interaction of shear and tension will not reduce allowable tension load:

$$M_a = 2,526 \# * 4.375'' = 11,053'' \# > 9,515'' \#$$

DEVELOPS FULL CLAMP STRENGTH.

ALLOWABLE SUBSTITUTIONS: Alternative concrete anchors may be designed for project conditions.

CONCRETE ANCHORS SHALL BE CHECKED FOR PROJECT CONDITIONS.

EDWARD C. ROBISON, PE

10012 Creviston Dr NW

Gig Harbor, WA 98329

253-858-0855/Fax 253-858-0856 elrobison@narrows.com

TO WOOD:

For 3/8" SS bolts to wood beams with bearing plates between bolt head and beam and framing has adequate strength to resist the loads:

Tension strength of 3/8" bolts (ASTM F 593)

$$T_n = 0.0775 \text{ in}^2 * 70 \text{ ksi} = 5,425 \#$$

$$T_s = 5,425 \# / 2 = 2,713 \#$$

Allowable moment based on anchor strength:

$$M_s = 2 * 2,713 \# * 3.75'' = 20,344'' \#$$

For 3/8" Lag screws:

For 8,400''# design load

$$T_{200} = \frac{8,400}{2 * 4.375''} = 960 \#$$

Adjustment for wood bearing (assumes Hem-fir or similar wood):

$$a = 2 * 960 / (1.075 * 625 \text{ psi} * 5'') = 0.572''$$

$$T = 8,400 / [2 * (4.375 - 0.572 / 2)] = 1,027 \#$$

Required embed depth will depend on wood density and moisture content:

Withdrawal strength of 3/8" lag screw to wood with $G \geq 0.46$

$C_D = 1.6$ for guard impact loads and wind loads

$W = 269$ pli from NDS Table 11.2A

$$W' = 1.6 * 269 = 430 \# / \text{in}$$

$$Z_{\perp} = 170 \# \text{ (NDS Table 11K)}$$

$$Z'_{\perp} = 1.6 * 170 \# = 272 \# \text{ each}$$

Shear load will equal wind or live load - assume 100# per lag:

Combined lateral and withdrawal loads (NDS Table 11.4)

$$Z'_{\perp} = (W'Z') / [W' \cos^2 \alpha + Z' \sin^2 \alpha]$$

$$\text{Resultant} = \sqrt{(1027^2 + 100^2)} = 1,032 \#$$

$$\alpha = \tan^{-1}(1027/100) = 84.4^\circ$$

Try assuming 3" embedment: $W'e = 430 * 3 = 1,290 \#$

$$Z'_{\perp} = (272 * 1,290) / [1,290 \cos^2 84.4^\circ + 272 \sin^2 84.4^\circ] = 1,246 \# \geq 1,032 \#$$

3" embedment assumption is good.

For protected installations the minimum embedment is 3" with

Allowable shear load = 400#

Allowable moment = 8,400''#

For weather exposed installations the minimum embedment is:

$$l_e = 3'' / C_M = 3 / 0.7 = 4.286''$$

Lesser embedment will reduce allowable load by:

$M' = l_e / 3'' * 8,400'' \#$ for moisture content always below 19%

$M' = l_e / 4.286'' * 8,400'' \#$ for moisture content that may go over 19%

Minimum embedment depth $l_e \geq 2.375''$ with reduced allowable moment load.

EDWARD C. ROBISON, PE

10012 Creviston Dr NW

Gig Harbor, WA 98329

253-858-0855/Fax 253-858-0856 elrobison@narrows.com

AFWC4S

One piece surface mounted clamp. Clamp body is similar to the AFWC1 clamp.

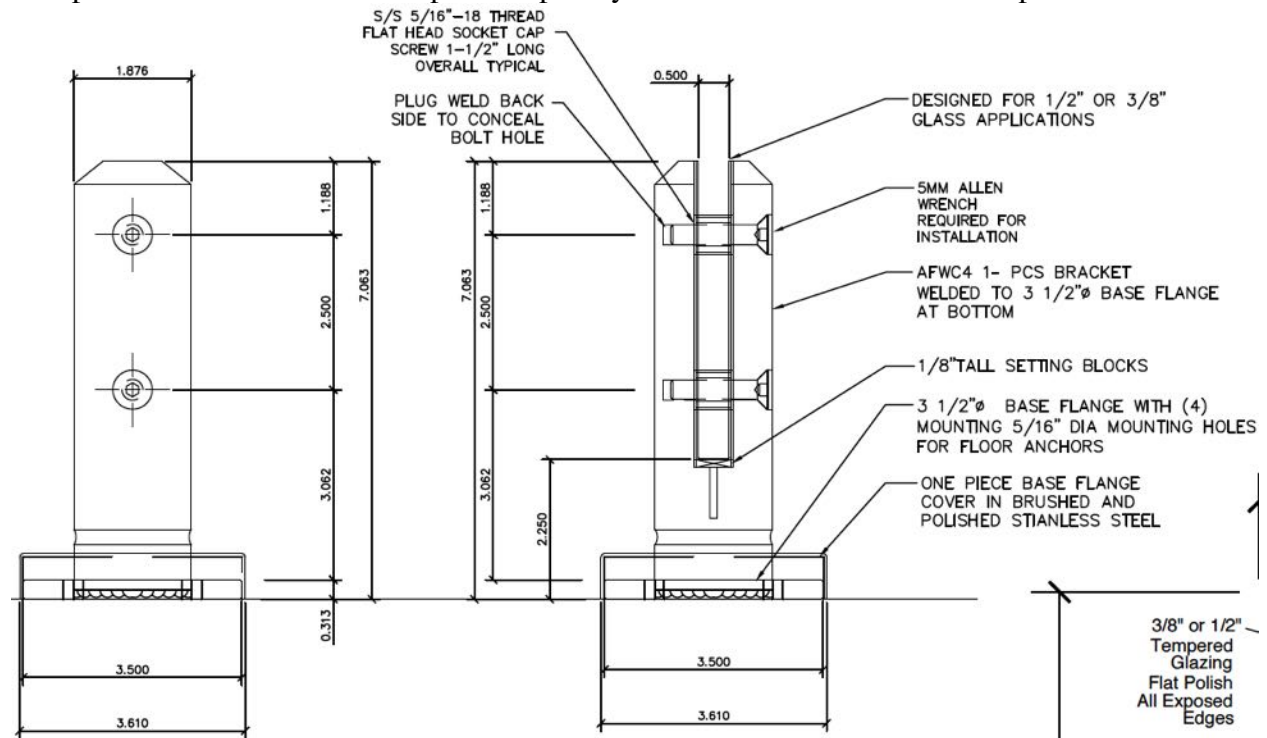

Clamp must be installed with bolt through the glass.

Check moment strength of clamp body

Glass to bracket moment resisted by tension in cap screws:

Screw tension is proportional to distance from bottom screw to screw being considered:

5/16" diameter cap screws connecting side plate to main clamp body

$$T_{5/16} = 3,980\# \text{ (ASTM F 879 Table 3)}$$

$$T_a = 3,980\#/2 = 1,990\#$$

Moment resistance M_a

$$M_a = 1,990\# * (3.312'' + 0.812''^2 / 3.312'') = 6,987''\#$$

Check for bending of side bars:

$$Z = 0.114 \text{ in}^3$$

$$F_y = 30 \text{ ksi For cast 316 SS}$$

$$M_n = 0.114 * 30 \text{ ksi} = 3,420''\#$$

$$M_s = 3,420 / 1.67 = 2,048''\#$$

Moment Strength of fully installed clamp:

$$M_s = 2 * 2,048 = 4,096''\#$$

EDWARD C. ROBISON, PE

10012 Creviston Dr NW

Gig Harbor, WA 98329

253-858-0855/Fax 253-858-0856 elrobison@narrows.com

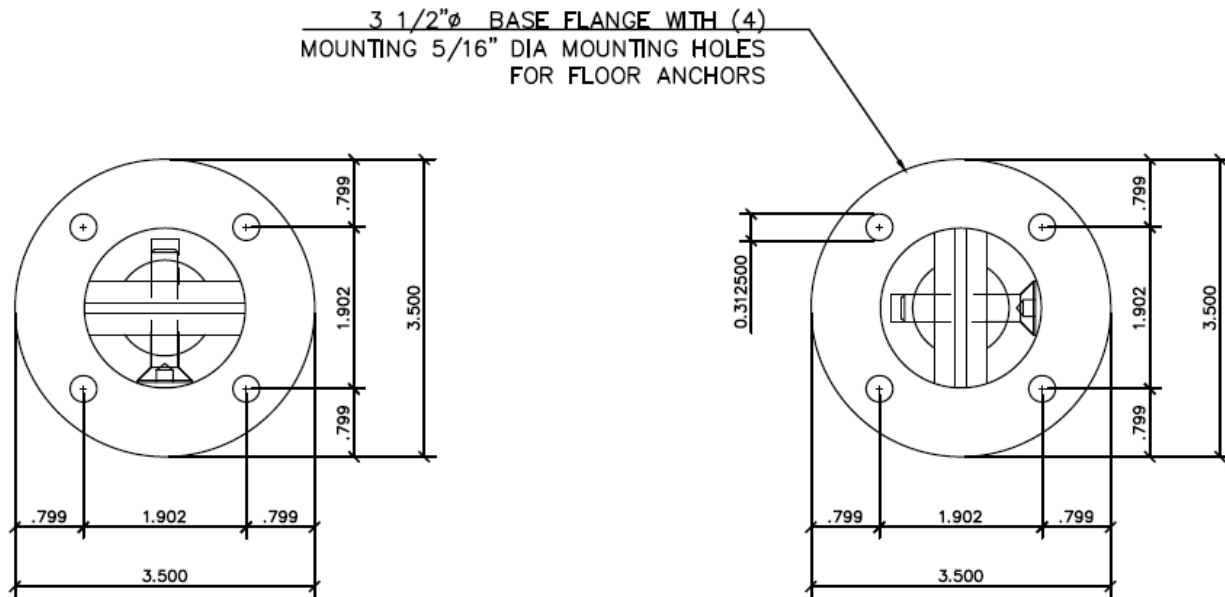

CONNECTION TO STEEL:

3/8” SS Bolts to steel framing with sufficient strength to properly support the imposed loads-
Tension strength of 3/8” bolts (ASTM F 593)

$$T_n = 0.0775 \text{ in}^2 * 70 \text{ ksi} = 5,425 \#$$

$$T_s = 5,425 \# / 2 = 2,713 \#$$

Allowable moment based on anchor strength:

$$M_s = 2 * 2,713 \# * 1.902'' = 10,320'' \#$$

BASE PLATE MOUNTED TO CONCRETE -

Base plate mounted to concrete with Hilti HUS anchors with 3” embedment. Anchor strength based on ESR-3027 and ACI 318-08 Appendix D.

Minimum conditions used for the calculations:

$$f'_c \geq 3,000 \text{ psi}; \text{ edge distance} = 2.25'' \quad \text{spacing} = 1.902''$$

$$h = 3.0''; \text{ embed depth}$$

For concrete breakout strength:

$$N_{cb} = [A_{Ncg} / A_{Nco}] \phi_{ed,N} \phi_{c,N} \phi_{cp,N} N_b$$

$$A_{Ncg} = (1.5 * 3 * 2 + 1.902) * (1.5 * 3 + 2.25) = 73.589 \text{ in}^2 \quad 2 \text{ anchors}$$

$$A_{Nco} = 9 * 3^2 = 81 \text{ in}^2$$

$$C_{a,cmin} = 1.5'' \quad (\text{ESR-3027 Table 2})$$

$$C_{ac} = 3.2'' \quad (\text{ESR-3027 Table 2})$$

$$\phi_{ed,N} = 1.0$$

$$\phi_{c,N} = (\text{use } 1.0 \text{ in calculations with } k = 24)$$

$$\phi_{cp,N} = \max (1.5 / 3.2 \text{ or } 1.5 * 2.25'' / 3.2) = 1.05 \text{ but } \leq 1.0$$

$$N_b = 24 * 1.0 * \sqrt{3000} * 3.0^{1.5} = 6,830 \#$$

$$N_{cb} = 73.589 / 81 * 1.0 * 1.0 * 0.857 * 6,830 = 5,318$$

based on concrete breakout strength.

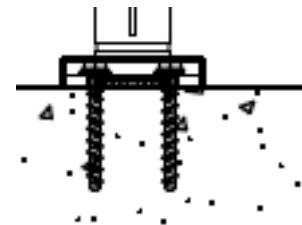

EDWARD C. ROBISON, PE

10012 Creviston Dr NW

Gig Harbor, WA 98329

253-858-0855/Fax 253-858-0856 elrobison@narrows.com

Steel strength:

$$T_{ns} = 9,200\# \text{ each}$$

Pullout strength - Per ESR-3027 Table 3 will not limit tension strength.

Determine allowable tension load on anchor pair

$$T_s = 0.65 * 5,318\# / 1.6 = 2,160\#$$

Check shear strength - Concrete breakout strength in shear:

$$V_{cb} = A_{vc} / A_{vco} (\phi_{ed,v} \phi_{c,v} \phi_{h,v} V_b)$$

$$A_{vc} = (1.5 * 3 * 2 + 3.75) * (2.25 * 1.5) = 43.03$$

$$A_{vco} = 4.5 (c_{a1})^2 = 4.5 (3)^2 = 40.5$$

$$\phi_{ed,v} = 1.0 \text{ (affected by only one edge)}$$

$$\phi_{c,v} = 1.4 \text{ uncracked concrete}$$

$$\phi_{h,v} = \sqrt{1.5 c_{a1} / h_a} = \sqrt{1.5 * 3 / 3} = 1.225$$

$$V_b = [7 (l_e / d_a)^{0.2} \sqrt{d_a}] \lambda \sqrt{f'_c} (c_{a1})^{1.5} = [7 (1.625 / 0.375)^{0.2} \sqrt{0.375}] 1.0 \sqrt{3000} (3.0)^{1.5} = 1,636\#$$

$$V_{cb} = 43.03 / 40.5 * 1.0 * 1.4 * 1.225 * 1,636\# = 2,981\#$$

$$\text{Steel shear strength} = 5,185 * 2 = 10,370\#$$

Allowable shear strength

$$\phi V_N / 1.6 = 0.70 * 2,981\# / 1.6 = 1,304\#$$

$$\text{Shear load} = 250 / 1,304 = 0.19 \leq 0.2$$

Therefore interaction of shear and tension will not reduce allowable tension load for shear loads under 250#

$$M_a = 2,160\# * 1.902'' = 4,108''\# > 4,096''\#$$

DEVELOPS FULL CLAMP STRENGTH.

ALLOWABLE SUBSTITUTIONS: Alternative concrete anchors may be designed for project conditions.

CONCRETE ANCHORS SHALL BE CHECKED FOR PROJECT CONDITIONS.

EDWARD C. ROBISON, PE

10012 Creviston Dr NW

Gig Harbor, WA 98329

253-858-0855/Fax 253-858-0856 elrobison@narrows.com

TO WOOD:

For 3/8" SS bolts to wood beams with bearing plates between bolt head and beam and framing has adequate strength to resist the loads:

Tension strength of 3/8" bolts (ASTM F 593)

$$T_n = 0.0775 \text{ in}^2 * 70 \text{ ksi} = 5,425 \#$$

$$T_s = 5,425 \# / 2 = 2,713 \#$$

Allowable moment based on anchor strength:

$$M_s = 2 * 2,713 \# * 1.902'' = 10,282'' \#$$

For 3/8" Lag screws:

For 4,096''# design load based on clamp strength

$$T_{200} = \frac{4,096}{2 * 2.30''} = 890 \#$$

Adjustment for wood bearing (assumes Hem-fir or similar wood):

$$a = 2 * 890 / (1.075 * 625 \text{ psi} * 2.5'') = 1.06''$$

$$T = 4,096 / [2 * (2.701 - 1.06/2)] = 943 \#$$

Required embed depth will depend on wood density and moisture content:

Withdrawal strength of 3/8" lag screw to wood with $G \geq 0.46$

$C_D = 1.6$ for guard impact loads and wind loads

$W = 269$ pli from NDS Table 11.2A

$$W' = 1.6 * 269 = 430 \# / \text{in}$$

$$Z_{\perp} = 170 \# \text{ (NDS Table 11K)}$$

$$Z'_{\perp} = 1.6 * 170 \# = 272 \# \text{ each}$$

Shear load will equal wind or live load - assume 63# per lag:

Combined lateral and withdrawal loads (NDS Table 11.4)

$$Z'_{\perp} = (W'Z') / [W' \cos^2 \alpha + Z' \sin^2 \alpha]$$

$$\text{Resultant} = \sqrt{(943^2 + 63^2)} = 945 \#$$

$$\alpha = \tan^{-1}(943/63) = 86.2^\circ$$

$$\text{Try assuming 3'' embedment: } W'e = 430 * 3 = 1,290 \#$$

$$Z'_{\perp} = (272 * 1,290) / [1290 \cos^2 86.2^\circ + 272 \sin^2 86.2^\circ] = 1,266 \# \geq 945 \#$$

3" embedment assumption is good.

For protected installations the minimum embedment is $3'' * 945 / 1266 = 2.24$ but not less than 2.375" with Allowable shear load = 250# and Allowable moment = 4,096''#

For weather exposed installations the minimum embedment is:

$$l_e = 3'' / C_M = 2.24 / 0.7 = 3.2''$$

Lesser embedment will reduce allowable load by:

no reduction for moisture content always below 19%

$$M' = l_e / 3.2 * 4,096'' \# \text{ for moisture content that may go over 19\%}$$

Minimum embedment depth $l_e \geq 2.375''$ with reduced allowable moment load.

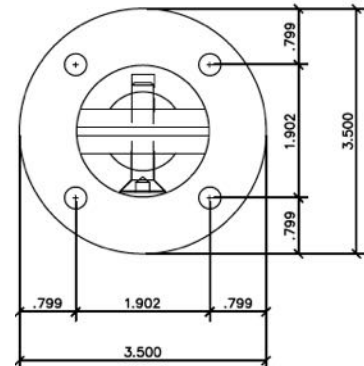

EDWARD C. ROBISON, PE

10012 Creviston Dr NW

Gig Harbor, WA 98329

253-858-0855/Fax 253-858-0856 elrobison@narrows.com

FRICION FIT CLAMPS**FWCR10**

One piece stainless steel clamp for installation into cored hole. Glass is locked into clamp by tightening two set screws which press a bearing plate against the glass.

Check for bending of side bars:

$$Z = 0.140 \text{ in}^3$$

$$F_y = 45 \text{ ksi For 316 SS based on tested strength}$$

$$M_n = 0.140 * 45 \text{ ksi} = 6,300 \text{''\#}$$

$$M_s = 6,300 / 1.67 = 3,772 \text{''\#}$$

Allowable shear load:

$$V_a = 0.6 * 45 \text{ ksi} * 0.309 \text{ in}^2 / 2 = 4,171 \text{ \#}$$

Anchorage is achieved by embedding clamp base into hole in concrete and grouted in place.



Moment is resisted by pry out from concrete. The grooves on the end of the rod prevent withdrawal.

From $\sum M$ about centroid of C_1 :

$$M_n = C_1 * D(2/3)$$

$$C_u = \phi F_B$$

F_B = shear block failure from ACI 318 App D.6.2

$$F_B = 2 * 1.4 * 7(3.5/1.875)^{0.2}(1.875 * 2500)^{1/2} * 3.5^{1.5} = 9,956 \text{ \#}$$

$$C_u = 0.85 * 9,956 \text{ \#} = 8,463 \text{ \#}$$

$$M_n = 8,463 \text{ \#} * 3.5 * (2/3) = 19,746 \text{''\#}$$

$$M_s = 0.70 * 19,746 / 1.6 = 8,639 \text{''\#}$$

NOTE ON CLAMP STRENGTH

The clamps were tested as part of a balustrade assembly in Australia by Azuma Design Pty Ltd, test reports revision date 18 April 2012. Based on the test reports the allowable moment for the clamp may be calculated as:

$$\text{Maximum test load} = 3.6 \text{ kN (809.3 lbs)}$$

$$\text{Maximum moment} = 3.6 \text{ kN} * 1035 \text{ mm} = 3.7778 \text{ kN-m (809.3 \#} * 40.75 \text{''} = 32,979 \text{''\#)}$$

Load resisted by 3 glass lights with two clamps on each.

Based on load distribution from top rail to glass, glass to clamp the load to the center for clamps are assumed equal and the end clamps receive 1/2 the load of the middle clamps.

Maximum clamp moment = $32,979 \text{''\#} / 4 = 8,245 \text{''\#}$ (test report indicated yielding of clamp occurred at the final test load but ultimate strength of the clamp wasn't reached)

$$SF = 8,245 / 3,772 = 2.19$$

Recommended design moment on clamp $M_a = 3,772 \text{''\#}$

Allowable shear load: $V_a = 3,772 / 6.875 \text{''} = 549 \text{ \#}$

EDWARD C. ROBISON, PE

10012 Creviston Dr NW

Gig Harbor, WA 98329

253-858-0855/Fax 253-858-0856 elrobison@narrows.com

FWCR12

Very similar to FWCR10 except slightly taller dimensions and fabricated from 2205 Duplex Stainless Steel. Dimensions on the image to the right with the single asterisk refer to the FWCR12 and double asterisks refer to FWCR10.

For 2205 Duplex Steel, $F_y = 65\text{ksi}$

$$M_n = 0.140 * 65\text{ksi} = 9,100\text{''}\#$$

$$M_s = 9,100 / 1.67 = 5,450\text{''}\#$$

Anchorage calculations are the same as for the FWCR10.

Recommended design moment on clamp $M_a = 5,450\text{''}\#$

Allowable shear load: $V_a = 5,450\text{''}\# / 7.875\text{''} = 692\text{#}$

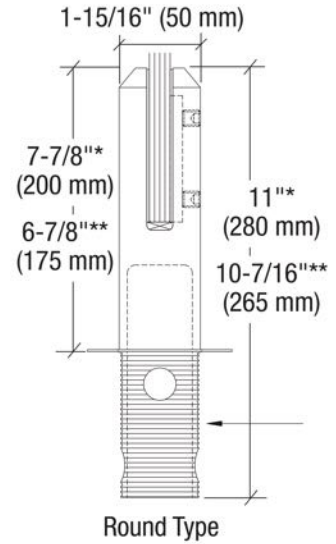

FWCS10

One piece stainless steel clamp for installation into cored hole. Glass is locked into clamp by tightening two set screws which press a bearing plate against the glass.

Check for bending of side bars:

$$Z = 0.192 \text{ in}^3$$

$$F_y = 45 \text{ ksi For 316 SS based on tested strength}$$

$$M_n = 0.192 * 45 \text{ ksi} = 8,640 \text{''\#}$$

$$M_s = 8,640 / 1.67 = 5,174 \text{''\#}$$

Allowable shear load:

$$V_a = 0.6 * 45 \text{ ksi} * 1.117 \text{ in}^2 / 2 = 15,082 \text{ \#}$$

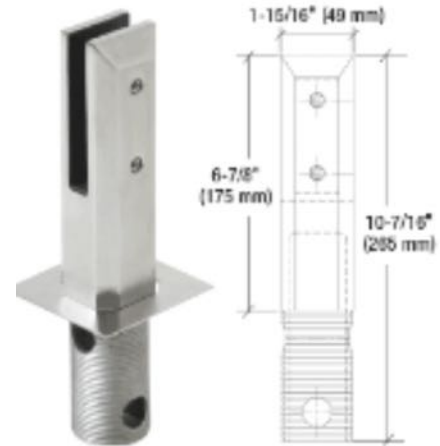

Anchorage is achieved by embedding clamp base into hole in concrete and grouted in place.

Moment is resisted by pry out from concrete. The grooves on the end of the rod prevent withdrawal.

From $\sum M$ about centroid of C_1 :

$$M_n = C_1 * D(2/3)$$

$$C_u = \phi F_B$$

F_B = shear block failure from ACI 318 App D.6.2

$$F_B = 2 * 1.4 * 7(3.5/1.875)^{0.2}(1.875 * 2500)^{1/2} * 3.5^{1.5} = 9,956 \text{ \#}$$

$$C_u = 0.85 * 9,956 \text{ \#} = 8,463 \text{ \#}$$

$$M_n = 8,463 \text{ \#} * 3.5 * (2/3) = 19,746 \text{''\#}$$

$$M_s = 0.70 * 19,746 / 1.6 = 8,639 \text{''\#}$$

NOTE ON CLAMP STRENGTH

Based on the tests performed on the FWCR10 clamps and that the FWCR10 clamps are fabricated by the same methods from the same stainless steel grade and type the moment strength of the clamp may be calculated the same way. Thus as demonstrated for the FWCR10 clamp the yield strength of 45 ksi is appropriate.

Recommended design moment on clamp $M_a = 5,174 \text{''\#}$

Allowable shear load: $V_a = 5,174 / 6.875 \text{''} = 753 \text{ \#}$

EDWARD C. ROBISON, PE

10012 Creviston Dr NW

Gig Harbor, WA 98329

253-858-0855/Fax 253-858-0856 elrobison@narrows.com

FWCS12

Very similar to FWCS10 except slightly taller dimensions and fabricated from 2205 Duplex Stainless Steel. Dimensions on the image to the right with the single asterisk refer to the FWCS12 and double asterisks refer to FWCS10.

For 2205 Duplex Steel, $F_y = 65\text{ksi}$

$$M_n = 0.192 * 65\text{ksi} = 12,500''\#$$

$$M_s = 12,500 / 1.67 = 7,480''\#$$

Anchorage strength is slightly reduced for the FWCS12 because the baseplates are slightly smaller.

$$\text{Reduction} = (1.902'' - (4.3125'' - 3.8125'') / 2) / 1.902'' = 0.869$$

$$\text{Anchorage to steel strength, } M_a = 10,300''\# * 0.869 = 8,950''\#$$

$$\text{Anchorage to concrete strength, } M_a = 4,108''\# * 0.869 = 3,570''\# \text{ (Less than clamp strength)}$$

$$\text{Required lag screw embedment to achieve clamp strength, } P = 2.05'' / 0.869 = 2.36'' \text{ (Not to be less than } 2\text{-}3/8'')$$

$$\text{Recommended design moment on clamp } M_a = 7,480''\#$$

$$\text{Allowable shear load: } V_a = 7,480''\# / 7.0625'' = 1,060\#$$

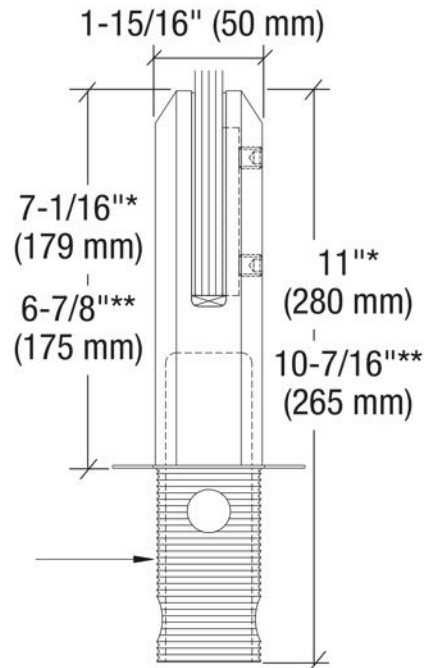

EDWARD C. ROBISON, PE

10012 Creviston Dr NW

Gig Harbor, WA 98329

253-858-0855/Fax 253-858-0856 elrobison@narrows.com

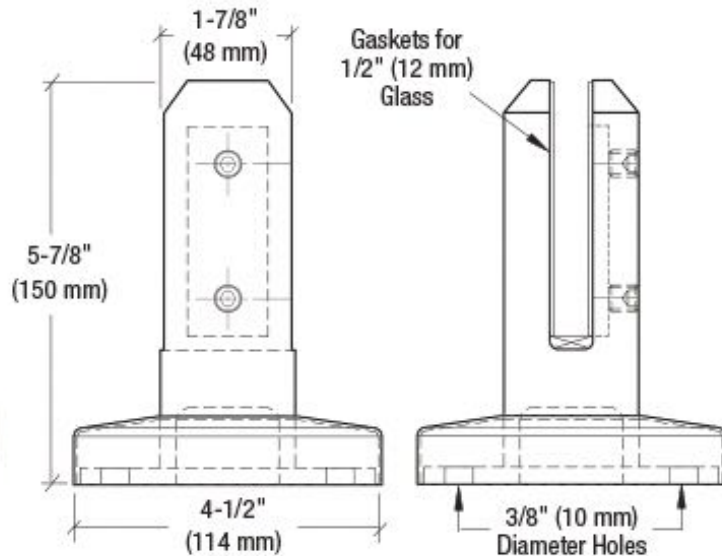

FWCR20

One piece stainless steel clamp with base shoe for surface mounting. Glass is locked into clamp by tightening two set screws which press a bearing plate against the glass.

Check for bending of side bars:

$$Z = 0.140 \text{ in}^3$$

$$F_y = 45 \text{ ksi For 316 SS}$$

$$M_n = 0.140 * 45 \text{ ksi} = 6,300 \text{ \#}$$

$$M_s = 6,300 / 1.67 = 3,772 \text{ \#}$$

Allowable shear load:

$$V_a = 0.6 * 45 \text{ ksi} * 0.309 \text{ in}^2 / 2 = 4,171 \text{ \#}$$

Strength of base plate mounts:

CONNECTION TO STEEL:

3/8" SS Bolts to steel framing with sufficient strength to properly support the imposed loads-

Tension strength of 3/8" bolts (ASTM F 593)

$$T_n = 0.0775 \text{ in}^2 * 70 \text{ ksi} = 5,425 \text{ \#}$$

$$T_s = 5,425 \text{ \#} / 2 = 2,713 \text{ \#}$$

Allowable moment based on anchor strength:

$$M_s = 2 * 2,713 \text{ \#} * 1.902 \text{ \#} = 10,320 \text{ \#}$$

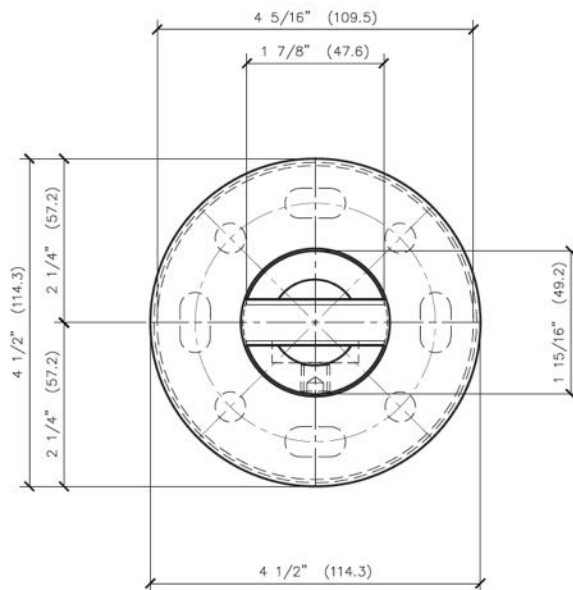

BASE PLATE MOUNTED TO CONCRETE -

Base plate mounted to concrete with Hilti HUS anchors with 3" embedment. Anchor strength based on ESR-3027 and ACI 318-08 Appendix D.

Minimum conditions used for the calculations:

$$f'_c \geq 3,000 \text{ psi; edge distance} = 2.25 \text{ \#} \text{ spacing} = 1.902 \text{ \#}$$

$$h = 3.0 \text{ \#}: \text{ embed depth}$$

For concrete breakout strength:

$$N_{cb} = [A_{Ncg} / A_{Nco}] \phi_{ed,s} N \phi_{c,s} N \phi_{cp,s} N N_b$$

EDWARD C. ROBISON, PE

10012 Creviston Dr NW

Gig Harbor, WA 98329

253-858-0855/Fax 253-858-0856 elrobison@narrows.com

$$A_{Ncg} = (1.5 \times 3 \times 2 + 1.902) \times (1.5 \times 3 + 2.25) = 73.589 \text{ in}^2 \text{ 2 anchors}$$

$$A_{Nco} = 9 \times 3^2 = 81 \text{ in}^2$$

$$C_{a,cmin} = 1.5'' \text{ (ESR-3027 Table 2)}$$

$$C_{ac} = 3.2'' \text{ (ESR-3027 Table 2)}$$

$$\phi_{ed,N} = 1.0$$

$$\phi_{c,N} = (\text{use } 1.0 \text{ in calculations with } k = 24)$$

$$\phi_{cp,N} = \max(1.5/3.2 \text{ or } 1.5 \times 2.25''/3.2) = 1.05 \text{ but } \leq 1.0$$

$$N_b = 24 \times 1.0 \times \sqrt{3000} \times 3.0^{1.5} = 6,830\#$$

$$N_{cb} = 73.589/81 \times 1.0 \times 1.0 \times 0.857 \times 6,830 = 5,318$$

based on concrete breakout strength.

Steel strength:

$$T_{ns} = 9,200\# \text{ each}$$

Pullout strength - Per ESR-3027 Table 3 will not limit tension strength.

Determine allowable tension load on anchor pair

$$T_s = 0.65 \times 5,318\#/1.6 = 2,160\#$$

Check shear strength - Concrete breakout strength in shear:

$$V_{cb} = A_{vc}/A_{vco}(\phi_{ed,v}\phi_{c,v}\phi_{h,v}V_b)$$

$$A_{vc} = (1.5 \times 3 \times 2 + 3.75) \times (2.25 \times 1.5) = 43.03$$

$$A_{vco} = 4.5(c_{a1})^2 = 4.5(3)^2 = 40.5$$

$$\phi_{ed,v} = 1.0 \text{ (affected by only one edge)}$$

$$\phi_{c,v} = 1.4 \text{ uncracked concrete}$$

$$\phi_{h,v} = \sqrt{1.5c_{a1}/h_a} = \sqrt{1.5 \times 3/3} = 1.225$$

$$V_b = [7(1_e/d_a)^{0.2}\sqrt{d_a}]\lambda\sqrt{f'_c}(c_{a1})^{1.5} = [7(1.625/0.375)^{0.2}\sqrt{0.375}]1.0\sqrt{3000}(3.0)^{1.5} = 1,636\#$$

$$V_{cb} = 43.03/40.5 \times 1.0 \times 1.4 \times 1.225 \times 1,636\# = 2,981\#$$

$$\text{Steel shear strength} = 5,185 \times 2 = 10,370\#$$

Allowable shear strength

$$\phi V_N/1.6 = 0.70 \times 2,981\#/1.6 = 1,304\#$$

$$\text{Shear load} = 250/1,304 = 0.19 \leq 0.2$$

Therefore interaction of shear and tension will not reduce allowable tension load for shear loads under 250#

$$M_a = 2,160\# \times 1.902'' = 4,108''\# > 3,772''\#$$

DEVELOPS FULL CLAMP STRENGTH.

ALLOWABLE SUBSTITUTIONS: Alternative concrete anchors may be designed for project conditions.

CONCRETE ANCHORS SHALL BE CHECKED FOR PROJECT CONDITIONS.

EDWARD C. ROBISON, PE

10012 Creviston Dr NW

Gig Harbor, WA 98329

253-858-0855/Fax 253-858-0856 elrobison@narrows.com

TO WOOD:

For 3/8" SS bolts to wood beams with bearing plates between bolt head and beam and framing has adequate strength to resist the loads:

Tension strength of 3/8" bolts (ASTM F 593)

$$T_n = 0.0775 \text{ in}^2 * 70 \text{ ksi} = 5,425 \#$$

$$T_s = 5,425 \# / 2 = 2,713 \#$$

Allowable moment based on anchor strength:

$$M_s = 2 * 2,713 \# * 1.902'' = 10,282'' \#$$

For 3/8" Lag screws:

For 3,772" design load based on clamp strength

$$T_{200} = \frac{3,772}{2 * 2.30''} = 820 \#$$

Adjustment for wood bearing (assumes Hem-fir or similar wood):

$$a = 2 * 820 / (1.075 * 625 \text{ psi} * 2.5'') = 0.976''$$

$$T = 3,772 / [2 * (2.701 - 0.976 / 2)] = 852 \#$$

Required embed depth will depend on wood density and moisture content:

Withdrawal strength of 3/8" lag screw to wood with $G \geq 0.46$

$C_D = 1.6$ for guard impact loads and wind loads

$W = 269 \text{ pli}$ from NDS Table 11.2A

$$W' = 1.6 * 269 = 430 \# / \text{in}$$

$$Z_{\perp} = 170 \# \text{ (NDS Table 11K)}$$

$$Z'_{\perp} = 1.6 * 170 \# = 272 \# \text{ each}$$

Shear load will equal wind or live load - assume 75# per lag:

Combined lateral and withdrawal loads (NDS Table 11.4)

$$Z'_{\perp} = (W'Z') / [W' \cos^2 \alpha + Z' \sin^2 \alpha]$$

$$\text{Resultant} = \sqrt{(852^2 + 75^2)} = 855 \#$$

$$\alpha = \tan^{-1}(855/75) = 85.0^\circ$$

$$\text{Try assuming 3'' embedment: } W'e = 430 * 3 = 1,290 \#$$

$$Z'_{\perp} = (272 * 1,290) / [1290 \cos^2 85^\circ + 272 \sin^2 85^\circ] = 1,254 \# \geq 855 \#$$

3" embedment assumption is good.

For protected installations the minimum embedment is $3'' * 855 / 1254 = 2.05''$ but not under 2.375" with Allowable shear load = 300# and Allowable moment = 3,772" #

For weather exposed installations the minimum embedment is:

$$l_e = 3'' / C_M = 2.05 / 0.7 = 2.93''$$

Lesser embedment will reduce allowable load by:

No reduction below 2.375" for moisture content always below 19%

$M' = l_e / 4.286 * 2.93'' \#$ for moisture content that may go over 19%

Minimum embedment depth $l_e \geq 2.375''$ with reduced allowable moment load.

EDWARD C. ROBISON, PE

10012 Creviston Dr NW

Gig Harbor, WA 98329

253-858-0855/Fax 253-858-0856 elrobison@narrows.com

FWCR22

Very similar to FWCS20 except slightly taller dimensions and fabricated from 2205 Duplex Stainless Steel. Dimensions on the image to the right with the single asterisk refer to the FWCR22 and double asterisks refer to FWCS20.

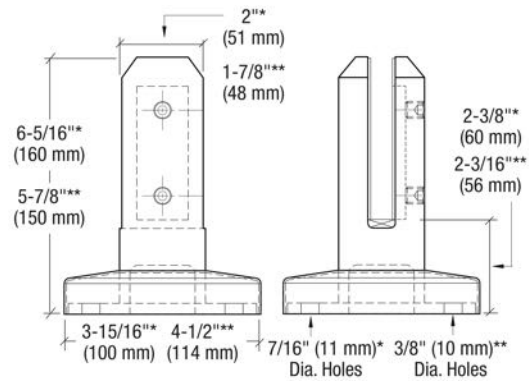

For 2205 Duplex Steel, $F_y = 65\text{ksi}$

$$M_n = 0.140 * 65\text{ksi} = 9,100''\#$$

$$M_s = 9,100 / 1.67 = 5,450''\#$$

Anchorage strength is slightly reduced for the FWCR22 because the baseplates are slightly smaller.

$$\text{Reduction} = (1.902'' - (4.3125'' - 3.8125'') / 2) / 1.902'' = 0.869$$

$$\text{Anchorage to steel strength, } M_a = 10,300''\# * 0.869 = 8,950''\#$$

$$\text{Anchorage to concrete strength, } M_a = 4,108''\# * 0.869 = 3,570''\# \text{ (Less than clamp strength)}$$

$$\text{Required lag screw embedment to achieve clamp strength, } P = 2.05'' / 0.869 = 2.36'' \text{ (Not to be less than } 2-3/8'')$$

$$\text{Recommended design moment on clamp } M_a = 5,450''\#$$

$$\text{Allowable shear load: } V_a = 5,450''\# / 6.3125'' = 863\#$$

EDWARD C. ROBISON, PE

10012 Creviston Dr NW

Gig Harbor, WA 98329

253-858-0855/Fax 253-858-0856 elrobison@narrows.com

FWCS20

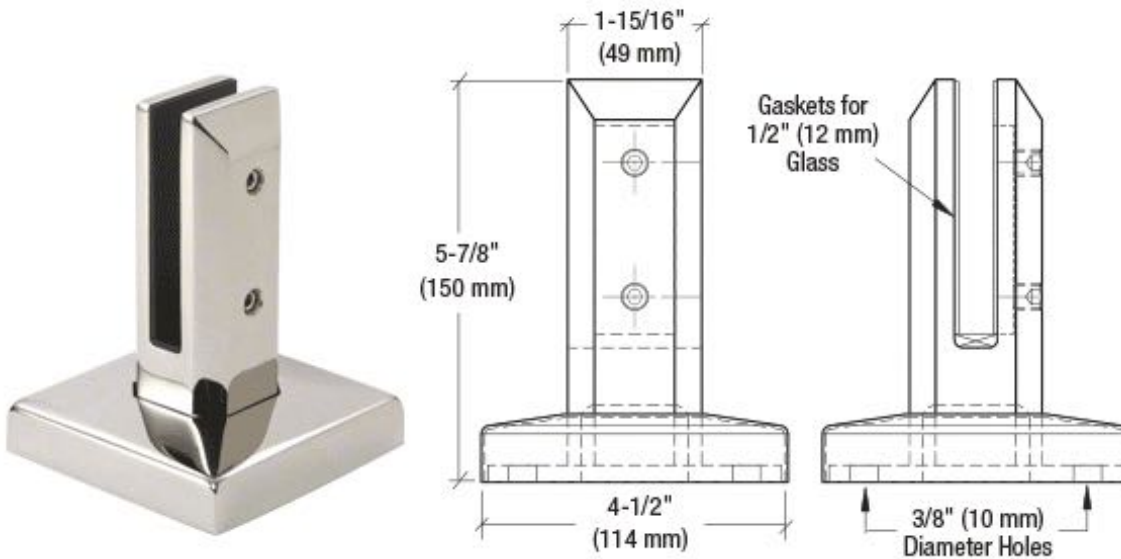

One piece stainless steel clamp with base shoe for surface mounting. Glass is locked into clamp by tightening two set screws which press a bearing plate against the glass.

Check for bending of side bars:

$$Z = 0.192 \text{ in}^3$$

$F_y = 45 \text{ ksi}$ For 316 SS based on tested strength

$$M_n = 0.192 * 45 \text{ ksi} = 8,640 \text{''\#}$$

$$M_s = 8,640 / 1.67 = 5,174 \text{''\#}$$

Allowable shear load:

$$V_a = 0.6 * 45 \text{ ksi} * 1.117 \text{ in}^2 / 2 = 15,082 \text{ \#}$$

Strength of base plate mounts:

CONNECTION TO STEEL:

3/8" SS Bolts to steel framing with sufficient strength to properly support the imposed loads-

Tension strength of 3/8" bolts (ASTM F 593)

$$T_n = 0.0775 \text{ in}^2 * 70 \text{ ksi} = 5,425 \text{ \#}$$

$$T_s = 5,425 \text{ \#} / 2 = 2,713 \text{ \#}$$

Allowable moment based on anchor strength:

$$M_s = 2 * 2,713 \text{ \#} * 1.902 \text{''} = 10,320 \text{''\#}$$

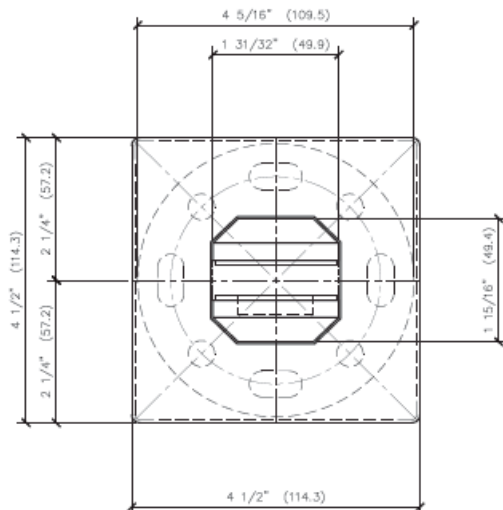

BASE PLATE MOUNTED TO CONCRETE -

Base plate mounted to concrete with Hilti HUS anchors with 3" embedment. Anchor strength based on ESR-3027 and ACI 318-08 Appendix D.

Minimum conditions used for the calculations:

$$f'_c \geq 3,000 \text{ psi}; \text{ edge distance} = 2.25 \text{''} \text{ spacing} = 1.902 \text{''}$$

$$h = 3.0 \text{''}: \text{ embed depth}$$

EDWARD C. ROBISON, PE

10012 Creviston Dr NW

Gig Harbor, WA 98329

253-858-0855/Fax 253-858-0856 elrobison@narrows.com

For concrete breakout strength:

$$N_{cb} = [A_{Ncg}/A_{Nco}] \phi_{ed,N} \phi_{c,N} \phi_{cp,N} N_b$$

$$A_{Ncg} = (1.5 \cdot 3 \cdot 2 + 1.902) \cdot (1.5 \cdot 3 + 2.25) = 73.589 \text{ in}^2 \text{ 2 anchors}$$

$$A_{Nco} = 9 \cdot 3^2 = 81 \text{ in}^2$$

$$C_{a,cmin} = 1.5'' \text{ (ESR-3027 Table 2)}$$

$$C_{ac} = 3.2'' \text{ (ESR-3027 Table 2)}$$

$$\phi_{ed,N} = 1.0$$

$$\phi_{c,N} = (\text{use } 1.0 \text{ in calculations with } k = 24)$$

$$\phi_{cp,N} = \max(1.5/3.2 \text{ or } 1.5 \cdot 2.25''/3.2) = 1.05 \text{ but } \leq 1.0$$

$$N_b = 24 \cdot 1.0 \cdot \sqrt{3000} \cdot 3.0^{1.5} = 6,830\#$$

$$N_{cb} = 73.589/81 \cdot 1.0 \cdot 1.0 \cdot 0.857 \cdot 6,830 = 5,318$$

based on concrete breakout strength.

Steel strength:

$$T_{ns} = 9,200\# \text{ each}$$

Pullout strength - Per ESR-3027 Table 3 will not limit tension strength.

Determine allowable tension load on anchor pair

$$T_s = 0.65 \cdot 5,318\#/1.6 = 2,160\#$$

Check shear strength - Concrete breakout strength in shear:

$$V_{cb} = A_{vc}/A_{vco} (\phi_{ed,v} \phi_{c,v} \phi_{h,v} V_b)$$

$$A_{vc} = (1.5 \cdot 3 \cdot 2 + 3.75) \cdot (2.25 \cdot 1.5) = 43.03$$

$$A_{vco} = 4.5(c_{a1})^2 = 4.5(3)^2 = 40.5$$

$$\phi_{ed,v} = 1.0 \text{ (affected by only one edge)}$$

$$\phi_{c,v} = 1.4 \text{ uncracked concrete}$$

$$\phi_{h,v} = \sqrt{(1.5c_{a1}/h_a)} = \sqrt{(1.5 \cdot 3/3)} = 1.225$$

$$V_b = [7(l_e/d_a)^{0.2} \sqrt{d_a}] \lambda \sqrt{f'_c} (c_{a1})^{1.5} = [7(1.625/0.375)^{0.2} \sqrt{0.375}] 1.0 \sqrt{3000} (3.0)^{1.5} = 1,636\#$$

$$V_{cb} = 43.03/40.5 \cdot 1.0 \cdot 1.4 \cdot 1.225 \cdot 1,636\# = 2,981\#$$

$$\text{Steel shear strength} = 5,185 \cdot 2 = 10,370\#$$

Allowable shear strength

$$\phi V_N/1.6 = 0.70 \cdot 2,981\#/1.6 = 1,304\#$$

$$\text{Shear load} = 250/1,304 = 0.19 \leq 0.2$$

Therefore interaction of shear and tension will not reduce allowable tension load for shear loads under 250#

$$M_a = 2,160\# \cdot 1.902'' = 4,108''\# < 5,174''\#$$

LIMITS CLAMP STRENGTH.

ALLOWABLE SUBSTITUTIONS: Alternative concrete anchors may be designed for project conditions.

CONCRETE ANCHORS SHALL BE CHECKED FOR PROJECT CONDITIONS.

EDWARD C. ROBISON, PE

10012 Creviston Dr NW

Gig Harbor, WA 98329

253-858-0855/Fax 253-858-0856 elrobison@narrows.com

TO WOOD:

For 3/8" SS bolts to wood beams with bearing plates between bolt head and beam and framing has adequate strength to resist the loads:

Tension strength of 3/8" bolts (ASTM F 593)

$$T_n = 0.0775 \text{ in}^2 * 70 \text{ ksi} = 5,425 \#$$

$$T_s = 5,425 \# / 2 = 2,713 \#$$

Allowable moment based on anchor strength:

$$M_s = 2 * 2,713 \# * 1.902'' = 10,282'' \#$$

For 3/8" Lag screws:

For 5,174''# design load based on clamp strength

$$T_{200} = \frac{5,174}{2 * 2.30''} = 1,125 \#$$

Adjustment for wood bearing (assumes Hem-fir or similar wood):

$$a = 2 * 1,125 / (1.075 * 625 \text{ psi} * 2.5'') = 1.34''$$

$$T = 4,096 / [2 * (2.701 - 1.34/2)] = 1,008 \#$$

Required embed depth will depend on wood density and moisture content:

Withdrawal strength of 3/8" lag screw to wood with $G \geq 0.46$

$C_D = 1.6$ for guard impact loads and wind loads

$W = 269$ pli from NDS Table 11.2A

$$W' = 1.6 * 269 = 430 \# / \text{in}$$

$$Z_{\perp} = 170 \# \text{ (NDS Table 11K)}$$

$$Z'_{\perp} = 1.6 * 170 \# = 272 \# \text{ each}$$

Shear load will equal wind or live load - assume 67# per lag:

Combined lateral and withdrawal loads (NDS Table 11.4)

$$Z'_{\perp} = (W'Z') / [W' \cos^2 \alpha + Z' \sin^2 \alpha]$$

$$\text{Resultant} = \sqrt{(1008^2 + 67^2)} = 1,010 \#$$

$$\alpha = \tan^{-1}(1,010/67) = 86.2^\circ$$

Try assuming 3" embedment: $W'e = 430 * 3 = 1,290 \#$

$$Z'_{\perp} = (272 * 1,290) / [1290 \cos^2 86.2^\circ + 272 \sin^2 86.2^\circ] = 1,266 \# \geq 1,010 \#$$

3" embedment assumption is good.

For protected installations the minimum embedment is $3'' * 1010 / 1266 = 2.4''$ with

Allowable shear load = 268#

Allowable moment = 5,174''#

For weather exposed installations the minimum embedment is:

$$l_e = 3'' / C_M = 2.4 / 0.7 = 3.42''$$

Lesser embedment will reduce allowable load by:

$$M' = l_e / 2.4'' * 5,425'' \# \text{ for moisture content always below 19\%}$$

$$M' = l_e / 3.42'' * 5,425'' \# \text{ for moisture content that may go over 19\%}$$

Minimum embedment depth $l_e \geq 2.375''$ with reduced allowable moment load.

EDWARD C. ROBISON, PE

10012 Creviston Dr NW

Gig Harbor, WA 98329

253-858-0855/Fax 253-858-0856 elrobison@narrows.com

FWCS22

Very similar to FWCS20 except slightly taller dimensions and fabricated from 2205 Duplex Stainless Steel. Dimensions on the image to the right with the single asterisk refer to the FWCS22 and double asterisks refer to FWCS20.

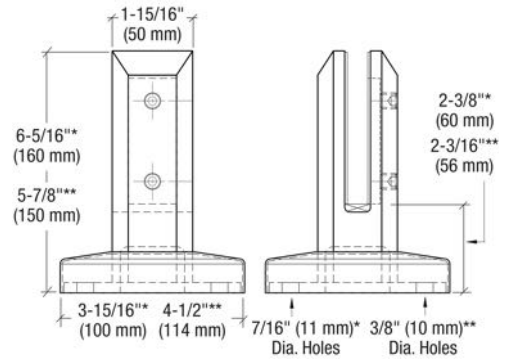

For 2205 Duplex Steel, $F_y = 65\text{ksi}$

$$M_n = 0.192 * 65\text{ksi} = 12,500''\#$$

$$M_s = 12,500 / 1.67 = 7,480''\#$$

Anchorage strength is slightly reduced for the FWCS22 because the baseplates are slightly smaller.

$$\text{Reduction} = (1.902'' - (4.3125'' - 3.8125'') / 2) / 1.902'' = 0.869$$

$$\text{Anchorage to steel strength, } M_a = 10,300''\# * 0.869 = 8,950''\#$$

$$\text{Anchorage to concrete strength, } M_a = 4,108''\# * 0.869 = 3,570''\# \text{ (Less than clamp strength)}$$

$$\text{Required lag screw embedment to achieve clamp strength, } P = 2.4'' / 0.869 = 2.76''$$

$$\text{Recommended design moment on clamp } M_a = 7,480''\#$$

$$\text{Allowable shear load: } V_a = 7,480''\# / 6.3125'' = 1,180\#$$

EDWARD C. ROBISON, PE

10012 Creviston Dr NW

Gig Harbor, WA 98329

253-858-0855/Fax 253-858-0856 elrobison@narrows.com

TABLE 15: CLAMP STRENGTH SUMMARY TABLE

CLAMP STYLE	BOLTS THRU GLASS		NO BOLTS THRU GLASS	
	SHEAR LBS	MOMENT IN-LBS	SHEAR LBS	MOMENT IN-LBS
AFWC1 AND AFWC6	1194	8,222	597	2,874
AFWC2 AND AFWC7	TO STEEL 478	TO STEEL 9,453	N/A	N/A
AFWC2 AND AFWC7	CONCRETE 108	CONCRETE 2,803	N/A	N/A
AFWC2 AND AFWC7	WOOD 78	WOOD 4,228	N/A	N/A
AFWC3 AND AFWC8	1194	4,974	597	2,487
DFWC3	1194	7,458	597	3,729
AFWC1S	400	8,400	400	2,874
AFWC4	597	5,964	N/A	N/A
AFWC4S	400	4,096	400	2,048
FWCR10	N/A	N/A	549	3,772
FWCS10	N/A	N/A	753	5,174
FWCR20 TO STEEL	N/A	N/A	1000	3,772
FWCR20 CONCRETE	N/A	N/A	600	3,772
FWCR20 WOOD	N/A	N/A	600	3,772
FWCS20 TO STEEL	N/A	N/A	1000	5,174
FWCS20 CONCRETE	N/A	N/A	250	4,108
FWCS20 WOOD	N/A	N/A	268	5,174

EDWARD C. ROBISON, PE

10012 Creviston Dr NW

Gig Harbor, WA 98329

253-858-0855/Fax 253-858-0856 elrobison@narrows.com

Appendix

Determination of moment and deflection amplification factors

36" Wide 50plf

Height	36	42	48	60
Mave	1800	2100	2400	3000
Calculated Stress	4090.90909090909	4772.72727272727	5454.54545454545	6818.18181818182
Stress by FEA	8729	10250	11920	15110
β	2.13375555555556	2.14761904761905	2.18533333333334	2.21613333333333
Calculated Defl.	0.724776969032481	1.15091898323213	1.71798985252144	3.35544893070593
Defl. by FEA	0.726	1.153	1.720	3.358
λ	1.00168745837654	1.00180813488889	1.00117005782986	1.00076027659689

36" Wide 10psf

Height	36	42	48	60
Mave	540	735	960	1500
Calculated Stress	1227.27272727273	1670.45454545455	2181.81818181818	3409.09090909091
Stress by FEA	2431	3358	4512	7213
β	1.98081481481481	2.010231292517	2.068	2.11581333333333
Calculated Defl.	0.163074818032308	0.302116233098435	0.515396955756431	1.25829334901472
Defl. by FEA	0.162	0.300	0.513	1.255
λ	0.99340904962963	0.992995301587302	0.995349301679687	0.997382685828151

36" Wide 200# Concentrated - Overstressed at all heights

Height	36	42	48	60
Stress by FEA	14100	16040	18340	22530
Defl. by FEA	1.202	1.816	2.619	4.897

48" Wide 50plf

Height	36	42	48	60
Mave	1800	2100	2400	3000
Calculated Stress	4090.90909090909	4772.72727272727	5454.54545454545	6818.18181818182
Stress by FEA	11080	13150	15300	19280
β	2.70844444444445	2.7552380952381	2.805	2.82773333333333
Calculated Defl.	0.724776969032481	1.15091898323213	1.71798985252144	3.35544893070593
Defl. by FEA	0.823	1.288	1.901	3.646
λ	1.13552173311831	1.11910570488889	1.106525744148	1.08659081848489

48" Wide 10psf

Height	36	42	48	60
Mave	540	735	960	1500
Calculated Stress	1227.27272727273	1670.45454545455	2181.81818181818	3409.09090909091
Stress by FEA	3109	4344	5820	9257
β	2.53325925925925	2.60048979591836	2.6675	2.71538666666667
Calculated Defl.	0.163074818032308	0.302116233098435	0.515396955756431	1.25829334901472
Defl. by FEA	0.187	0.342	0.578	1.388
λ	1.14671291531322	1.13201464380952	1.12146568493345	1.10308140870874

60" Wide 50plf

Height	36	42	48	60
Mave	1800	2100	2400	3000
Calculated Stress	4090.90909090909	4772.72727272727	5454.54545454545	6818.18181818182
Stress by FEA	13700	16140	18690	23550
β	3.34888888888889	3.38171428571429	3.4265	3.454
Calculated Defl.	0.724776969032481	1.15091898323213	1.71798985252144	3.35544893070593
Defl. by FEA	0.932	1.442	2.106	3.978
λ	1.28591282535391	1.25291182177778	1.22585124522656	1.185534359828

60" Wide 10psf

Height	36	42	48	60
Mave	540	735	960	1500
Calculated Stress	1227.27272727273	1670.45454545455	2181.81818181818	3409.09090909091
Stress by FEA	3861	5350	7132	11330
β	3.14599999999999	3.20272108843537	3.26883333333334	3.32346666666667
Calculated Defl.	0.163074818032308	0.302116233098435	0.515396955756431	1.25829334901472
Defl. by FEA	0.215	0.390	0.652	1.539
λ	1.31841324487883	1.29089389206349	1.26504433663773	1.223085221904

68" Wide 50plf

Height	36	42	48	60
Mave	1800	2100	2400	3000
Calculated Stress	4090.90909090909	4772.72727272727	5454.54545454545	6818.18181818182
Stress by FEA	15430	18150	21020	26470
β	3.77177777777778	3.80285714285715	3.85366666666667	3.88226666666667
Calculated Defl.	0.724776969032481	1.15091898323213	1.71798985252144	3.35544893070593
Defl. by FEA	1.01	1.552	2.254	4.219
λ	1.39353213906379	1.34848761955556	1.31199843624913	1.25735783411622

68" Wide 10psf

Height	36	42	48	60
Mave	540	735	960	1500
Calculated Stress	1227.27272727273	1670.45454545455	2181.81818181818	12760
Stress by FEA	4355	6029	8031	11330
β	3.54851851851851	3.60919727891155	3.680875	0.887931034482759
Calculated Defl.	0.163074818032308	0.302116233098435	0.515396955756431	1.25829334901472
Defl. by FEA	0.238	0.423	0.704	1.648
λ	1.45945280130773	1.4001233752381	1.36593744324074	1.30971049103171

72" Wide 50plf

Height	36	42	48	60
Mave	1800	2100	2400	3000
Calculated Stress	4090.90909090909	4772.72727272727	5454.54545454545	6818.18181818182
Stress by FEA	16300	19170	22190	27940
β	3.98444444444445	4.01657142857143	4.06816666666667	4.09786666666667
Calculated Defl.	0.724776969032481	1.15091898323213	1.71798985252144	3.35544893070593
Defl. by FEA	1.05	1.609	2.331	4.344
λ	1.44872153070988	1.39801326022223	1.35681825860547	1.29461067347733

72" Wide 10psf

Height	36	42	48	60
Mave	540	735	960	1500
Calculated Stress	1227.27272727273	1670.45454545455	2181.81818181818	12760
Stress by FEA	4603	6370	8483	13470
β	3.75059259259258	3.81333333333332	3.88804166666667	1.05564263322884
Calculated Defl.	0.163074818032308	0.302116233098435	0.515396955756431	1.25829334901472
Defl. by FEA	0.25	0.441	0.730	1.704
λ	1.53303865683585	1.45970309333333	1.41638399654224	1.35421521645511